



US006919373B1

(12) **United States Patent**
Lam et al.

(10) **Patent No.:** **US 6,919,373 B1**

(45) **Date of Patent:** **Jul. 19, 2005**

(54) **METHODS AND DEVICES FOR PROVIDING
PROLONGED DRUG THERAPY**

4,036,228 A 7/1977 Theeuwes 128/260
4,063,064 A 12/1977 Saunders et al. 219/121 L

(75) Inventors: **Andrew C. Lam**, South San Francisco, CA (US); **Padmaja Shivanand**, Mountain View, CA (US); **Atul D. Ayer**, Palo Alto, CA (US); **Richard G. Weyers**, Los Altos, CA (US); **Suneel K. Gupta**, Sunnyvale, CA (US); **Diane R. Guinta**, Palo Alto, CA (US); **Carol A. Christopher**, Belmont, CA (US); **Samuel R. Saks**, Burlingame, CA (US); **Lawrence G. Hamel**, Mountain View, CA (US); **Jeri D. Wright**, Dublin, CA (US); **Zahedeh Hatamkhany**, San Jose, CA (US)

(Continued)

FOREIGN PATENT DOCUMENTS

BE	675379	5/1966
CA	1 169 090	6/1984
EP	0 094 123 A2	11/1983
EP	0 212 747 A3	3/1987
EP	0 212 747 A2	3/1987
EP	0 216 743 A3	4/1987
EP	0 216 743 A2	4/1987
EP	0 348 808 A3	1/1990
EP	0 348 808 A2	1/1990
EP	0 381 219 A2	8/1990
EP	0 381 219 A3	8/1990
EP	0 621 032 A1	10/1994
FR	2 598 319	5/1987
FR	2 620 25	9/1988
FR	2 635 460	5/1989
GB	2 206 046 A	12/1988
GB	2 206 047 A	12/1988
WO	91/03247 A1	3/1991
WO	92/01445 A1	2/1992
WO	92/04012 A1	3/1992
WO	92/18102 A1	10/1992
WO	93/05769 A1	4/1993
WO	95/19174 A1	7/1995
WO	95/20946 A1	8/1995
WO	98/06380 A2	2/1998
WO	98/14168 A2	4/1998
WO	98/14168 A3	4/1998
WO	98/23263 A1	6/1998
WO	99/62496 A1	12/1999

(73) Assignee: **Alza Corporation**, Mountain View, CA (US)

(*) Notice: Subject to any disclaimer, the term of this patent is extended or adjusted under 35 U.S.C. 154(b) by 0 days.

(21) Appl. No.: **09/253,317**

(22) Filed: **Feb. 19, 1999**

Related U.S. Application Data

(63) Continuation-in-part of application No. 09/070,666, filed on Apr. 30, 1998, now abandoned, which is a continuation-in-part of application No. 08/967,606, filed on Nov. 10, 1997, now abandoned, and a continuation-in-part of application No. 08/937,336, filed on Aug. 19, 1997, now abandoned, which is a continuation of application No. 08/910,593, filed on Jul. 31, 1997.

(60) Provisional application No. 60/044,121, filed on Apr. 22, 1997, provisional application No. 60/031,741, filed on Nov. 25, 1996, and provisional application No. 60/030,514, filed on Nov. 12, 1996.

(51) **Int. Cl.**⁷ **A61K 31/235**

(52) **U.S. Cl.** **514/532**

(58) **Field of Search** 514/532, 252

(56) **References Cited**

U.S. PATENT DOCUMENTS

2,507,631 A	5/1950	Hartmann	260/294
2,648,609 A	8/1953	Wurster	99/166
2,668,162 A	2/1954	Lowe	260/78.3
2,676,945 A	4/1954	Niggins	260/45.7
2,738,303 A	3/1956	Blythe	167/82
2,798,053 A	7/1957	Brown	260/2.2
2,799,241 A	7/1957	Wurster	118/24
2,909,462 A	10/1959	Warfield et al.	167/56
2,957,880 A	10/1960	Rometsch	260/294
2,996,431 A	8/1961	Barry	167/82
3,139,383 A	6/1964	Barry	424/462
3,625,214 A	12/1971	Higuchi	128/260
3,773,919 A	11/1973	Boswell et al.	424/19
3,811,444 A	5/1974	Heller et al.	128/26
3,825,068 A	7/1974	Norton et al.	166/305 R
3,845,770 A	11/1974	Theeuwes et al.	128/260
3,916,899 A	11/1975	Theeuwes et al.	128/260
3,962,414 A	6/1976	Michaels	424/19
3,992,518 A	11/1976	Chien et al.	424/22

OTHER PUBLICATIONS

Medline Abstract 89207694 (1989). Patrick et al.*
Patrick, K.S., et al., "The absorption of sustained-release methylphenidate formulations compared to an immediate-release formulation," *Biopharmaceutics & Drug Disposition*, 1989, 10, 165-171.
Drill, *Pharmacology in Medicine*, pp. 227 (1965) McGraw-Hill.
Goodman and Gilman's *The Basis of Therapeutics*, 8th ed., pp. 72 (1990) Pergamon Press.
Merck Index, 11th Edition, pp. 960, Item 6025 (1989).
Pharmaceutical Sciences by Remington, 17th ed., pp. 342-345 (1985).
Pharmaceutical Sciences by Remington, 17th ed., pp. 1603-1632 (1985).

(Continued)

Primary Examiner—Zohreh Fay
(74) *Attorney, Agent, or Firm*—Woodcock Washburn LLP

(57) **ABSTRACT**

Methods and devices for maintaining a desired therapeutic drug effect over a prolonged therapy period are provided. In particular, oral dosage forms that release drug within the gastrointestinal tract at an ascending release rate over an extended time period are provided. The dosage forms may additionally comprise an immediate-release dose of drug.

8 Claims, 2 Drawing Sheets

U.S. PATENT DOCUMENTS

4,066,747 A 1/1978 Capozza 424/78
 4,070,347 A 1/1978 Schmitt 260/77.5
 4,079,038 A 3/1978 Choi et al. 260/77.5
 4,083,949 A 4/1978 Benedikt 424/19
 4,088,864 A 5/1978 Theeuwes et al. ... 219/121 LM
 4,093,709 A 6/1978 Choi et al. 424/19
 4,111,201 A 9/1978 Theeuwes 424/473
 4,111,202 A 9/1978 Theeuwes 128/260
 4,137,300 A 1/1979 Sheth et al. 424/21
 4,200,098 A 4/1980 Ayer et al. 128/260
 4,285,987 A 8/1981 Ayer et al. 427/3
 4,327,725 A 5/1982 Cortese et al. 128/260
 4,434,153 A 2/1984 Urquhart et al. 424/22
 4,449,983 A 5/1984 Cortese et al. 604/892
 4,612,008 A 9/1986 Wong et al. 604/892
 4,721,613 A 1/1988 Urquhart et al. 424/19
 4,752,470 A 6/1988 Mehta 424/458
 4,783,337 A 11/1988 Wong et al. 424/468
 4,814,181 A 3/1989 Jordan et al. 424/473
 4,853,229 A 8/1989 Theeuwes 424/455
 5,017,381 A 5/1991 Maruyama et al. 424/472
 5,030,456 A 7/1991 Ayer et al. 424/473
 5,082,668 A 1/1992 Wong et al. 424/473
 5,089,270 A 2/1992 Hampton et al. 424/465
 5,094,786 A 3/1992 Nagashima et al. 264/40.2
 5,178,866 A 1/1993 Wright et al. 424/473
 5,294,770 A 3/1994 Riddle et al. 219/121.7
 5,399,828 A 3/1995 Riddle et al. 219/121.7
 5,422,831 A 6/1995 Misra et al. 364/552
 5,464,631 A 11/1995 Hoover et al. 424/454
 5,558,231 A 9/1996 Weier 209/580
 5,707,663 A 1/1998 Ayer et al. 424/473
 5,718,700 A 2/1998 Edgren et al. 604/892.1

5,770,227 A 6/1998 Dong et al. 424/480
 5,785,994 A 7/1998 Wong et al. 424/473
 5,824,338 A 10/1998 Jacobs et al. 424/460
 5,837,284 A 11/1998 Mehta et al. 424/459
 5,869,097 A 2/1999 Wong et al. 424/473
 5,874,090 A 2/1999 Baker et al. 424/400

OTHER PUBLICATIONS

Pharmaceutical Sciences by Remington, 17th ed., Ch. 68, pp. 1305–1306 (1985).
 Journal of the American Pharmaceutical Association, vol. 48, pp. 451–454 (1959).
 Journal of the American Pharmaceutical Association, vol. 49, pp. 83–84 (1960).
 Grafton, P./Boonton Molding Co., Modern Plastic Encyclopedia, vol. 46, pp. 62–70 (1969).
 Wurster, Dale E., The Pharmacological Basis of Therapeutics by Goodman and Gilman, 7th ed., Ch. 23, p. 534 (1940).
 Pharmaceutical Sciences, Remington, 14th Ed., pp. 1626–1679 (1970).
 S. Budavor. Ed., Merck Index 12th Edition, Merck Research Labs (New Jersey, USA) p. 1042 (Apr. 5, 1996).
 Unknown, “Product Information” Physician’s Desk Reference, Medical Economics Data (U.S.A.) p. 856–866 (Apr. 5, 1991).
 Roff et al., “Cellulose Esthers (I),” Handbook of Common Polymers, CRC Press (U.S.A.) pp. 164–173, (Apr. 5, 1971).
 Longer, M.A. et al., “Sustained Release Drug Delivery Systems,” pp. 1676–1686.
 Voigt, R: “Therapeutische Systeme.” Pharmazeutische Technologie, 1993, pp. 556–557.

* cited by examiner

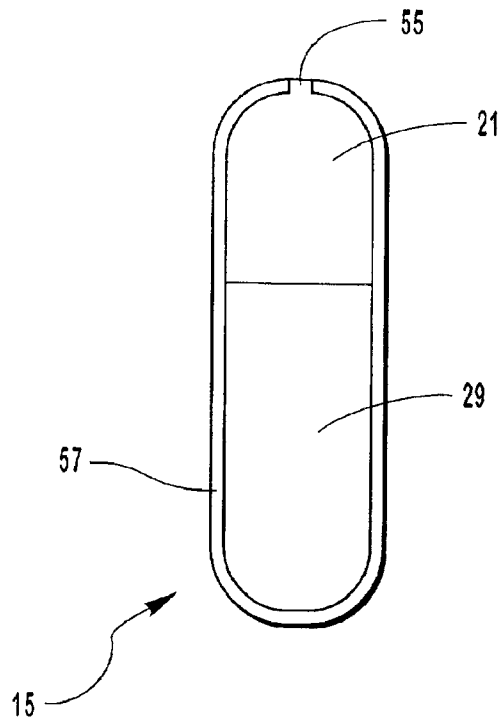

FIG. 1

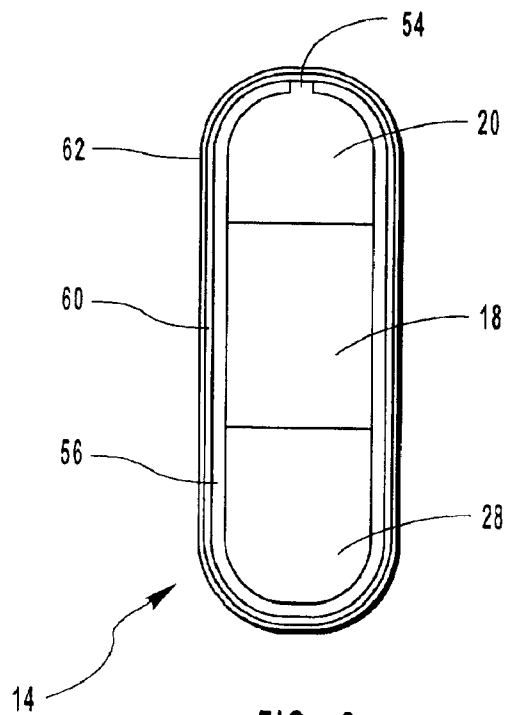

FIG. 2

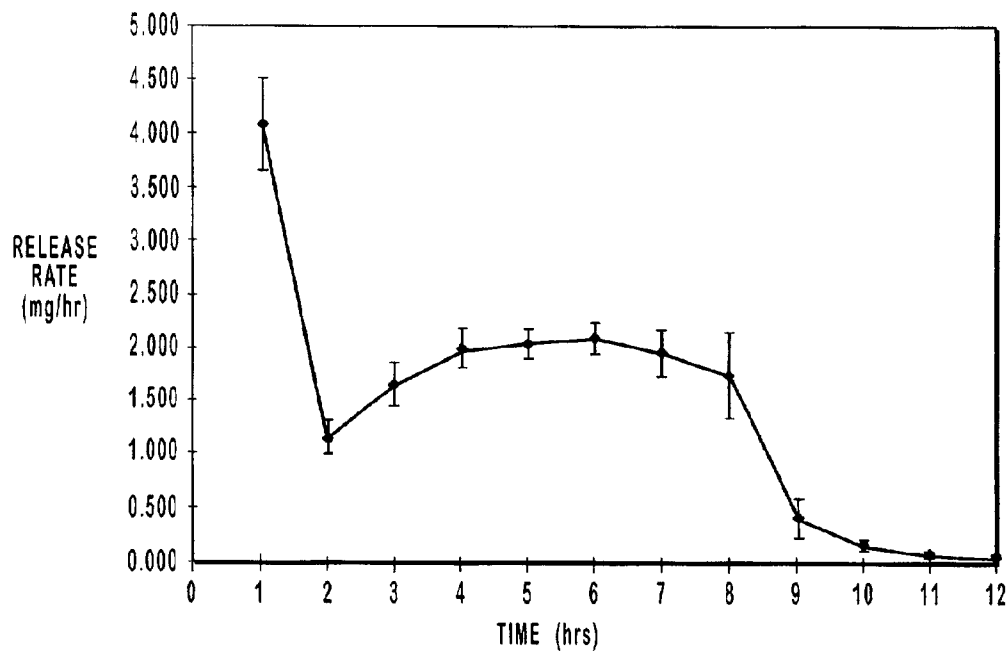

FIG. 3

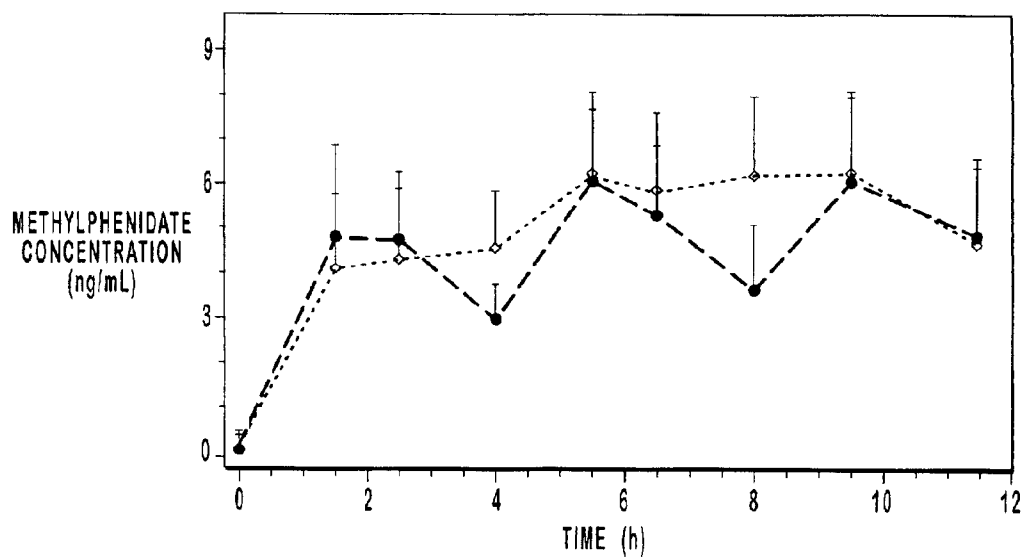

FIG. 4

METHODS AND DEVICES FOR PROVIDING PROLONGED DRUG THERAPY

CROSS-REFERENCE TO RELATED APPLICATIONS

This application is a continuation-in-part of U.S. application Ser. No. 09/070,666, filed Apr. 30, 1998, now abandoned, which is a continuation of U.S. application Ser. No. 08/910,593, filed Jul. 31, 1997, which claims the benefit of U.S. Provisional Application Nos. 60/030,514 and 60/044,121, filed Nov. 12, 1996 and Apr. 22, 1997, respectively.

This application is also a continuation-in-part of U.S. application Ser. No. 08/967,606, filed Nov. 10, 1997, now abandoned, which claims the benefit of U.S. Provisional Application No. 60/031,741, filed Nov. 25, 1996.

This application is also a continuation-in-part of U.S. application Ser. No. 08/937,336, filed Aug. 19, 1997, now abandoned.

BACKGROUND OF THE INVENTION

1. Field of the Invention

This invention pertains to methods and devices for maintaining a desired therapeutic drug effect over a prolonged therapy period. In particular, the invention is directed to methods and devices that provide drug release within the gastrointestinal tract at an ascending release rate over an extended time period. In this manner, drug is released at an ascending rate during a portion of the drug administration period sufficient to maintain a desired therapeutic drug effect throughout a prolonged therapy period.

2. Description of the Related Art Including Information Disclosed Under 37 CFR 1.97 and 1.98

To produce its pharmacological effects, a drug must be made available in appropriate concentrations at its site of action within the body. This availability is affected by numerous factors including the quantity of the drug administered, the extent and rate of its absorption from its administration site, its distribution, binding or localization within tissues, its biotransformation and its excretion. One commonly-used indicator of drug availability is the concentration of drug that is obtained within the blood or plasma, or other appropriate body fluid or tissue, of a patient following administration of the drug. For convenience, this concentration may be referred to as "plasma drug concentration" hereinafter which is intended to be inclusive of drug concentration measured in any appropriate body fluid or tissue. Plasma drug concentration measurements provide very useful information including, for example, comparative information with regard to different drug dosage forms and/or different drug administration routes. In addition, for many drugs, various drug effects including both desired pharmacological effects, i.e., therapeutic drug effects, and undesired pharmacological effects, i.e., side effects, have been correlated with specific plasma drug concentrations or ranges of plasma drug concentrations.

For orally administered drug dosage forms, absorption occurs within the gastrointestinal ("g.i.") tract and is affected by many factors including the physicochemical properties of the local microenvironment, such as surface area, blood flow and membrane characteristics (which vary significantly in the different portions of the g.i. tract), the physicochemical properties of the drug entity, drug concentration, the existence and activity of drug-specific transport mechanisms, etc. One important factor in the rate of absorption of drug

administered as an oral dosage form is the rate at which drug is released from the dosage form. Drug release rates for oral dosage forms are typically measured as an in vitro rate of dissolution, i.e., a quantity of drug released from the dosage form per unit time.

Conventional oral dosage forms can be described as "immediate-release" because, generally, essentially the entire dose of drug is released from the dosage form within a very short period, i.e., minutes, following administration. As this bolus of released drug is absorbed, the plasma drug concentration typically rapidly rises to a maximal or peak concentration and subsequently declines as the drug is distributed, bound or localized within tissues, biotransformed and/or excreted. The time period for this decline varies for different drugs and depends on many factors but this time period will be characteristic of a particular drug. Generally, during some portion of the time period in which the plasma drug concentration rises, peaks and declines, the drug provides its therapeutic effects, i.e., the plasma drug concentration achieves or exceeds an effective concentration. Moreover, at some point during this time period, the therapeutic effects disappear, i.e., when the plasma drug concentration declines to a level that is below an effective concentration. In addition, often, during a portion of this time surrounding the time the peak concentration is attained, i.e., when the plasma drug concentration is in its highest range, undesired side effects may become apparent.

In view of the above, it will be appreciated that continued drug effectiveness occurs during the time period when the plasma drug concentration is within the effective plasma drug concentration range. Because the plasma drug concentration declines over time, however, multiple doses of the immediate-release drug dosage form must be administered at appropriate intervals to ensure that the plasma drug concentration remains in or, again, rises to, the effective concentration range. At the same time, however, there is a need to avoid or minimize plasma drug concentrations that rise to, and/or that remain for too long within, the higher ranges where side effects become apparent. Accordingly, for many drugs, multiple, separate doses of the immediate-release dosage form must be administered at appropriate intervals to maintain a satisfactory balance of desired and undesired pharmacological effects over a prolonged therapy period.

One focus of efforts to improve drug therapy has been directed to providing non-immediate-release oral drug dosage forms that affect absorption of the drug primarily by altering the release rate of the drug from the dosage form. Examples of such non-immediate-release delivery systems include delayed-release and sustained-release systems. Sustained-release dosage forms generally release drug for an extended time period compared to an immediate-release dosage form. There are many approaches to achieving sustained release of drugs from oral dosage forms known in the art. These different approaches include, for example, diffusion systems such as reservoir devices and matrix devices, dissolution systems such as encapsulated dissolution systems (including, for example, "tiny time pills") and matrix dissolution systems, combination diffusion/dissolution systems, osmotic systems and ion-exchange resin systems as described in *Remington's Pharmaceutical Sciences*, 1990 ed., pp. 1682-1685.

It is believed to be particularly desirable to provide sustained-release oral dosage forms that provide drug release at a substantially constant release rate over an extended time period. In this manner, for many drugs, the plasma drug concentration initially ascends for a short

period of time as drug release begins and then remains substantially constant over an extended time period as drug release continues at a constant rate. For many drugs, this substantially constant plasma drug concentration correlates with substantially constant drug effectiveness over a prolonged therapy period. In addition, because an initial relatively high peak plasma drug concentration is avoided, side effects may be less of a problem. Accordingly, advantages of constant-release dosage forms include decreasing the number of doses of a drug that need to be administered over time and providing a better balance of desired and undesired pharmacological effects of the drug.

Osmotic dosage forms, in particular, have been notably successful at providing constant-release of drugs over extended time periods. Osmotic dosage forms, in general, utilize osmotic pressure to generate a driving force for imbibing fluid into a compartment formed, at least in part, by a semipermeable wall that permits free diffusion of fluid but not drug or osmotic agent(s), if present. A substantially constant rate of drug release can be achieved by designing the system to provide a relatively constant osmotic pressure and having suitable exit means for the drug formulation to permit the drug formulation to be released at a rate that corresponds to the rate of fluid imbibed as a result of the relatively constant osmotic pressure. A significant advantage to osmotic systems is that operation is pH-independent and thus continues at the osmotically-determined rate throughout an extended time period even as the dosage form transits the gastrointestinal tract and encounters differing microenvironments having significantly different pH values.

Surprisingly simple but highly effective osmotic devices comprising drug in a mixture with excipients, optionally including osmotically active component(s), within the compartment are known in the art. Although effective for many drugs, the release rate in these devices often declines over time and complete delivery of the drug load may not occur. A more sophisticated type of osmotic device comprises two component layers within the compartment formed by the semipermeable wall. One component layer comprises drug in a mixture with excipients, optionally including osmotically active component(s), that will form a deliverable drug formulation within the compartment and the second component layer comprises osmotically active component(s) but does not contain drug. The osmotically active component(s) in the second component layer typically comprise osmopolymers having relatively large molecular weights and which exhibit "swelling" as fluid is imbibed such that release of these components through the drug formulation exit means does not occur. The second component layer is referred to as a "push" layer since, as fluid is imbibed, the osmopolymer(s) swell and push against the deliverable drug formulation of the first component layer to thereby facilitate release of the drug formulation at a substantially constant rate. The above-described devices are known, for example, from the following US Patents, owned by Alza Corporation: U.S. Pat. Nos. 4,327,725; 4,612,008; 4,783,337; and 5,082,668, each of which is incorporated in its entirety by reference herein.

Although constant-release dosage forms have proven effective for many different drug therapies, there are clinical situations where these have not been entirely satisfactory. It has been observed that for some patients being treated with constant-release dosage forms for some conditions or diseases, the therapeutic effectiveness of the drug decreases at time periods before the end of the desired therapy period despite the maintenance of substantially constant drug release that would be expected to provide continued effective-

tiveness. Accordingly, there remains a need to provide methods and devices for maintaining a desired therapeutic drug effect over a desired prolonged therapy period when sustained-release dosage forms that release drug at a substantially constant rate over an extended time period are not satisfactory.

BRIEF SUMMARY OF THE INVENTION

One aspect of the present invention pertains to providing improved drug therapy for those clinical situations where therapeutic effectiveness of an administered drug therapy unexpectedly decreases at time periods before the end of the intended therapy period. It has been surprisingly discovered that, in an exemplary clinical situation, administration of drug at a release rate that is ascending, rather than substantially constant, over an extended time period provided therapeutic efficacy that did not decrease before the end of the prolonged therapy period.

With the discovery that administration of drug at a release rate that is substantially ascending provides improved drug therapy, a need arises for sustained-release oral dosage forms adapted to provide such a release rate over a suitable extended time period. Accordingly, other aspects of the present invention include providing oral sustained-release dosage forms that provide an ascending drug release rate over an extended time period, methods of making such dosage forms and methods of using such dosage forms to maintain therapeutic effectiveness for a desired prolonged therapy period.

It has been surprisingly discovered that oral osmotic dosage forms exhibiting an ascending drug release rate for an extended time period can be achieved. In particular, the present invention is directed to osmotic dosage forms having bi-layer or tri-layer tablet cores that are adapted to provide ascending drug release rates over an extended period. In addition, to provide for an initial rapid onset of drug action, the present invention is also related to dosage forms that additionally comprise a dose of drug for immediate release.

The bi-layer oral osmotic dosage forms of the present invention include a first component layer, comprising a selected drug and excipients for forming a deliverable drug composition when hydrated, and a second push layer, comprising a fluid-expandable osmopolymer and excipients, contained within a compartment formed by a semipermeable membrane and having exit means for drug release from the compartment. The two layers are compressed into bi-layer tablet cores before the semipermeable membrane is applied and a suitable orifice for drug release therethrough is formed. Importantly, the bi-layer tablet cores disclosed herein are formed when two component layers are compressed together to provide a longitudinally compressed tablet ("LCT") core having a "capsule-shaped" configuration with a different layer at each narrow end.

The combination of features including the osmotic properties of the component layers, the fluid flux properties of the semipermeable membrane and the configuration of the tablet core ensures that drug is released at an ascending rate over an extended time period. In a preferred embodiment, sufficient activity in the push layer is achieved by use of a relatively large concentration (at least about 35%) of osmotically effective solute, or osmagent, such as sodium chloride. In addition, sorbitol is preferably included in the first component layer.

The tri-layer oral osmotic dosage forms of the present invention include a novel tri-layer tablet core surrounded by a semipermeable membrane and having suitable exit means

5

for releasing drug formulation through the semipermeable membrane. The novel tri-layer tablet core has a first drug-containing layer, a second drug-containing layer and a third push layer. In operation, through the cooperation of the dosage form components, drug is successively released from the first drug-containing layer and then from the second drug-containing layer. It has been discovered that a drug concentration gradient facilitates the achievement of an ascending drug release rate for an extended time period. Consequently, the other excipients in the drug-containing layers may be more flexibly varied and adjusted for other purposes such as manufacturing convenience and pharmaceutical elegance. In this manner, dosage forms that exhibit reliable drug release having the desired sustained and ascending rate over an extended time period can be reliably and efficiently manufactured.

It is preferred to use the LCT core configuration, as described above, to enhance hydration of the tri-layer core. In addition, a flux-enhancing agent is preferably included in the semipermeable wall composition. In a presently preferred embodiment, the combination of features including the LCT tri-layer core configuration, a suitable drug concentration gradient between the first and second component layers, the osmotic properties of the component layers and the fluid flux properties of the semipermeable membrane achieves the desired ascending rate of drug release over an extended time period.

There are numerous clinical situations and drug therapies that could be improved with the use of dosage forms that provide a sustained and ascending release rate over an extended time period. Exemplary dosage forms, as disclosed herein, comprise CNS-acting drugs and cardiovascular-acting drugs. It will be appreciated by persons of skill in the art that the invention is applicable to many other types of drugs and drug therapies. Examples of suitable types of drugs include, but are not limited to, anti-infectives, analgesics, anesthetics, antiarthritics, antiasthmatics, anticonvulsants, antidepressants, antidiabetics, anti-diarrheals, antihistamines, antiinflammatories, antimigraines, antineoplastics, antiparkinsonisms, antipruritics, antipsychotics, antipyretics, antispasmodics, anticholinergics, sympathomimetics, calcium channel blockers, beta blockers, antiarrhythmics, antihypertensives, ACE inhibitors, diuretics, vasodilators, decongestants, hormones, hypnotics, immunosuppressants, parasymphomimetics, prostaglandins, proteins, peptides, sedatives and tranquilizers.

The exemplary clinical situation described herein involves treatment of ADHD with methylphenidate therapy. Accordingly, the present invention also pertains to making oral methylphenidate sustained release dosage forms that provide a sustained and ascending release rate of a drug over an extended time period.

It has further been discovered that oral methylphenidate sustained release dosage forms that provide an ascending release rate of a drug over an extended time period can be used to provide effective once-a-day therapy for ADHD. Thus, the present invention also pertains to improving drug therapy for ADHD by eliminating the need for multiple daily doses of methylphenidate yet providing therapeutic efficacy throughout the day that compares to the therapeutic efficacy provided by multiple doses of immediate release methylphenidate.

The above-described features and advantages, as well as others, will become more apparent from the following detailed disclosure of the invention and the accompanying claims.

6

Although the present invention is illustrated herein by exemplary dosage forms containing specific exemplary drugs, methods of making such dosage forms and methods of using methylphenidate-containing dosage forms to provide a desired therapeutic outcome, the invention is not limited by the exemplary embodiments. The invention broadly embraces oral sustained-release dosage forms that provide an ascending drug release rate over an extended time period, methods of making such dosage forms and methods of using such dosage forms to maintain therapeutic effectiveness for a desired prolonged therapy period with respect to any appropriate drugs and drug therapies as would be apparent to a person of skill in the art in view of the disclosure herein.

BRIEF DESCRIPTION OF THE SEVERAL VIEWS OF THE DRAWINGS

FIG. 1 is a cross-section view of a bi-layer osmotic dosage form in accord with the present invention.

FIG. 2 is a cross-section view of a tri-layer osmotic dosage form, additionally comprising an immediate-release drug overcoat and an aesthetic overcoat, in accord with the present invention.

FIG. 3 is a graph illustrating the quantity of drug released over time from a preferred embodiment of the present invention as described in Example 6.

FIG. 4 is a graph illustrating the plasma drug concentration over time obtained following administration of methylphenidate in accord with an experimental regimen (open diamonds) and a standard regimen (closed circles) as described in Example 7.

DETAILED DESCRIPTION OF THE INVENTION

Many effective drug therapies utilize immediate-release oral dosage forms administered at spaced intervals to provide and maintain a desired therapeutic effect over a prolonged therapy period. In addition, sustained-release dosage forms for many drugs are known and, in particular, constant-release oral dosage forms are known. There are many examples of effective drug therapies that utilize constant-release oral dosage forms to provide a desired therapeutic effect over a prolonged therapy period. In many cases, these drug therapies offer advantages over drug therapies that utilize immediate-release oral dosage forms administered at spaced intervals. There are clinical situations, however, where the constant-release dosage form has unexpectedly exhibited decreases in therapeutic effectiveness at time periods before the end of the desired prolonged therapy period.

One example of a clinical situation where drug therapy with sustained-release oral drug dosage forms that provide a substantially constant rate of drug release for an extended period has not been entirely satisfactory is with the use of central nervous system (CNS) stimulant drugs to treat various conditions and disorders including Attention Deficit Disorder (ADD) and Attention Deficit Hyperactivity Disorder (ADHD). These disorders are commonly diagnosed in children but can also occur in adults. Treatment of these and other psychological conditions with CNS stimulant drugs has a long history. About 25 years ago, methylphenidate replaced amphetamine as the primary stimulant prescribed to treat ADHD in children.

Methylphenidate therapy in children with ADHD has been extensively studied and the efficacy and safety of this

treatment is well-established. Methylphenidate therapy has been shown to be very effective in reducing symptoms of hyperactivity, inattention and impulsivity in children with ADHD. The goal of drug therapy is to control the behavioral symptoms during the daytime while the patient is in school or otherwise involved in activities where symptom control benefits the patient's ability to learn and/or otherwise beneficially participate in activities. Because of concerns related to side effects, however, drug therapy is typically discontinued during at least a portion of the evening and through the night in most patients. Depending on the patient's particular circumstances, drug therapy may or may not be discontinued over the weekends as well.

Treatment commonly utilizes immediate-release methylphenidate administered two or three times during the day. For various reasons, patients often experience difficulty complying with this administration schedule. Because of abuse potential, methylphenidate is a controlled substance and thus drug access is a special concern. This dosage regimen generally requires that at least one dose is administered during the school day and, as a rule, children are not permitted to self-administer the drug at school. For this reason, authorized school personnel generally take on the responsibility for administering the drug to children during the school day, however, this approach raises issues of medical privacy and potential stigmatizing of the child by peers. In addition, the compliance issue becomes further complicated as transportation, storage and supply of the drug typically must be documented and/or monitored and the schedules of the different parties involved, i.e., the child, the educators and the authorized school personnel, must be coordinated and accommodated. The unfortunate result is that doses may be given late or missed altogether resulting in decreased efficacy of the therapy.

For all of the above reasons, it would appear that a sustained-release oral dosage form of methylphenidate that provided substantially constant drug release over an extended period to thereby eliminate the need for dose administration during the school day would be a welcome improvement. In fact, such a sustained-release dosage form of methylphenidate has been commercially available for several years. Clinical experience with this dosage form, however, has been disappointing in that behavioral symptoms in patients taking the controlled-release dosage form is less well-controlled later in the day compared to those patients taking multiple doses of the immediate-release dosage form. In addition, the slower onset of action of the controlled-release dosage form compared to the immediate-release dosage form is unsatisfactory for many patients.

It has been surprisingly discovered that administration of methylphenidate at a release, rate that is substantially ascending, rather than substantially constant, over an extended time period provided therapeutic efficacy similar to the efficacy obtained with multiple doses of immediate-release methylphenidate dosage forms. Details of this discovery are disclosed in copending U.S. application Ser. No. 910,593, filed Jul. 31, 1997, of which the present application is a continuation-in-part application. To briefly review, in one clinical study, a comparison of the behavioral, attentional, and cognitive efficacy of placebo; and methylphenidate administered according to three different release rate regimens, i.e., immediate-release, constant-release and ascending-release, was performed. The immediate-release methylphenidate was administered as two spaced-apart doses. The constant-release regimen was administered as an initial loading dose with the remaining total quantity administered in equal small doses at closely-spaced intervals

extending past the time of administration of the second immediate-release dose. The ascending-release regimen was administered as an initial loading dose with the remaining total quantity administered in increasing small doses at closely-spaced intervals extending past the time of administration of the second immediate-release dose.

In this study, the constant-release regimen was observed to have decreased clinical effectiveness compared to the immediate-release regimen at evaluation periods following administration of the second immediate-release dose. On the other hand, the ascending-release regimen demonstrated comparable clinical efficacy to the immediate-release regimen during these evaluation periods. Thus, the ascending-release regimen avoided the decrease in therapeutic efficacy seen with the constant-release regimen at later time periods during the prolonged therapy period.

While not making any assertions with respect to mechanism(s) of action of the present invention, it is noted that the development of acute tolerance to methylphenidate has been proposed as an explanation for the unsatisfactory decrease in therapeutic effectiveness that has been observed in some cases. Support for this theory was demonstrated in a second clinical study wherein a decrease in effectiveness of methylphenidate was seen over a prolonged therapy period both when a constant-release regimen was utilized as well as when very closely-spaced doses of immediate-release methylphenidate dosage forms were administered. An ascending-release regimen, however, was shown to maintain therapeutic efficacy throughout the prolonged therapy period.

With the discovery that drug effectiveness over a prolonged therapy period may be improved in some circumstances with administration of drug in an ascending release rate over an extended period, a need arises for sustained-release oral dosage forms adapted to provide such a release rate. In one aspect of the present invention, it has been surprisingly discovered that bi-layer oral osmotic dosage forms can be adapted to meet this need. In another aspect, it has been surprisingly discovered that sustained-release oral osmotic dosage forms having novel tri-layer cores can be produced that also achieve sustained release of drug formulations at an ascending rate for an extended time period.

As is known in the prior art, osmotic dosage forms comprising compressed tablet cores require a short time period following administration in which to become hydrated sufficiently to begin releasing drug. For some drug therapies, the slight delay in initial drug release is unsatisfactory. This problem is overcome with the addition of an initial dose of drug supplied in an immediate-release overcoat applied to the surface of the semipermeable membrane. In preferred embodiments of the present invention, as disclosed herein, such an immediate-release drug overcoat is applied onto the surface of the bi-layer or tri-layer osmotic dosage forms.

For purposes of this disclosure, the following definitions shall apply:

For clarity and convenience herein, the convention is utilized of designating the time of drug administration as zero hours ($t=0$ hours) and times following administration in appropriate time units, e.g., $t=30$ minutes or $t=2$ hours, etc.

As used herein, the term "drug" generally refers to a pharmacologically active substance that, when delivered into a living organism, produces a desired, usually beneficial, effect. Drug compositions are generally utilized clinically in the form of a pharmaceutically acceptable salt thereof. In addition, some drug compositions exhibit chiral-

ity and, thus, have more than one optical isomer. Because the different optical isomers may exhibit different pharmacological effects, it may be advantageous to utilize a substantially pure form of one optical isomer of a drug, or a pharmaceutically acceptable salt thereof. Accordingly, the term “drug” refers to a clinically useful form of a drug composition including a pharmaceutically acceptable salt thereof and including a substantially pure isomer of the drug composition and a pharmaceutically acceptable salt thereof. Although a limited number of drugs are represented in the exemplary embodiments herein, the invention is not to be limited by the exemplary embodiments but is fully applicable to other suitable drugs as would be understood by persons of skill in the art.

The amount of drug incorporated in the dosage forms of the present invention varies depending on the particular drug, the therapeutic indication and the desired administration period, e.g., every 12 hours, every 24 hours, etc. Depending on the dose of drug desired to be administered, one or more of the dosage forms may be administered.

A drug “release rate” refers to the quantity of drug released from a dosage form per unit time, e.g., milligrams of drug released per hour (mg/hr). Drug release rates are calculated under in vitro dosage form dissolution testing conditions known in the art. As used herein, a drug release rate obtained at a specified time “following administration” refers to the in vitro drug release rate obtained at the specified time following implementation of an appropriate dissolution test. The dissolution test utilized in the Examples described herein were performed on dosage forms placed in metal coil sample holders attached to a USP Type VII bath indexer and immersed in about 50 ml of acidified water (pH=3) equilibrated in a constant temperature water bath at 37° C. Aliquots of the release rate solutions were injected into a chromatographic system to quantify the amounts of drug released during the testing intervals.

A commonly-used reference measurement for evaluating drug release from oral dosage forms is the time at which 90% of drug within a dosage form has been released. This measurement is referred to as the “ T_{90} ” for the dosage form.

An “immediate-release” dose of a drug refers to a dose that is substantially completely released within a time period of about 1 hour or less and, preferably, about 30 minutes or less. An immediate-release dose of drug applied as a coating on the surface of a dosage form, as used herein, refers to a dose of a drug prepared in a suitable pharmaceutically acceptable carrier to form a coating solution that will dissolve rapidly upon administration to thereby provide an immediate-release dose of drug. As is known in the art, such immediate-release drug overcoats may contain the same or a different drug or drugs as is contained within the underlying dosage form.

A “periodic release rate” refers to the quantity of drug released from a dosage form during a specified periodic interval as determined at the end of that specified periodic interval, i.e., at each periodic interval when a determination is made, the quantity of drug released represents the periodic release rate during that periodic interval. For example, the quantity of drug released as determined at t=1 h represents the periodic release rate from the dosage form during the first hour following administration and the quantity of drug released as determined at t=2 h represents the periodic release rate during the second hour following administration, etc.

An “ascending release rate” refers to a periodic release rate that is increased over the immediately-preceding peri-

odic release rate, where the periodic intervals are the same. For example, when the quantity of drug released from a dosage form is measured at hourly intervals and the quantity of drug released during the fifth hour following administration (determined at t=5 hours) is greater than the quantity of drug released from the dosage form during the fourth hour following administration (determined at t=4 hours), an ascending release rate from the fourth hour to the fifth hour has occurred.

It will be appreciated that the first periodic release rate measured, e.g., the periodic release rate at t=1 hour (unless equal to 0), will always be greater than the release rate during the preceding period, e.g., the hour before the dosage form was administered, and, thus, the first periodic release rate always constitutes an occurrence of an ascending release rate.

The ascending release rates described herein refer to the release rate from a dosage form adapted to provide sustained release of drug and do not include release of drug from any immediate-release drug coating that may be applied to the dosage form. In dosage form embodiments additionally comprising an immediate-release dose of a drug applied as a coating onto the underlying dosage form, the drug release measured at t=1 hour will generally reflect both the drug released from the immediate-release drug coating and any drug released from the underlying dosage form, however, the quantity of drug released from the drug overcoat is disregarded in determining whether the drug release rate at t=2 hours is greater than the drug release rate at t=1 hour.

As used herein with reference to the time period during which an ascending release rate is provided, “an extended time period” refers to a time period beginning at t=0 hours and continuing through at least the mid-point, and preferably beyond the mid-point, of the relevant T_{90} of the dosage form. Because the dosage forms of the present invention are intended to provide sustained release of drug, a suitable T_{90} for purposes of this invention is at least about 6 hours and, consequently, the “extended time period” during which an ascending release rate is provided is at least 3 hours.

In accord with the above-recited definitions, an “ascending release rate over an extended time period” refers to ascending release rates of drug obtained from the time of administration of the dosage form through, and preferably beyond, the mid-point of the relevant T_{90} for the dosage form. To illustrate, consider a situation where a dosage form has a T_{90} of about 8 hours. In this situation, “an ascending release rate over an extended time period” is achieved when the release rate at each hour through t=4 hours is greater than the release rate in the immediately-preceding hour. Preferably, the release rate continues to ascend during time periods beyond t=4 hours.

Bi-layer oral osmotic dosage forms and methods of making and using such dosage forms are known in the art, for example, as described and claimed in the following US Patents, owned by Alza Corporation: U.S. Pat. Nos. 4,327, 725; 4,612,008; 4,783,337; and 5,082,668, each of which is incorporated in its entirety by reference herein. The prior art bi-layer osmotic dosage forms achieve sustained release of drug formulations wherein a relatively brief initial period of ascending release rates is followed by substantially constant release rates over a major portion of the T_{90} period. The achievement of an ascending release rate for an extended time period of at least 50% of the T_{90} period is not found within the prior art. The dosage forms of the present invention are useful for providing continuous effective drug therapy over a prolonged therapy period without exhibiting

a decrease in effectiveness during the after portion of the prolonged therapy period.

The bi-layer oral osmotic dosage forms of the present invention include a first component layer, comprising a selected drug and excipients for forming a deliverable drug composition when hydrated, and a second push layer, comprising a fluid-expandable osmopolymer and excipients, wherein the two layers are compressed into bi-layer tablet cores before the semipermeable membrane is applied and a suitable orifice for drug release therethrough is formed. The combination of features including the osmotic properties of the component layers, the fluid flux properties of the semipermeable membrane and the configuration of the tablet core ensures that drug is released at an ascending rate over an extended time period.

Importantly, the bi-layer tablet cores of the present invention are configured such that each component layer is substantially round in cross-dimension with a circumferential width and a length between a top and a bottom end. The two layers are compressed together longitudinally such that the resulting bi-layer tablet core has the same circumferential width as the component layers and a length that combines the lengths of the component layers. The overall configuration can be described as "capsule-shaped" wherein the bi-layer tablet core has a circumferential width that is less than its length and has a rounded "narrow" top end and a rounded "narrow" bottom end and wherein each narrow end comprises a different component tablet layer.

For purposes of this disclosure, the above-described tablet cores are referred to as longitudinally compressed tablet ("LCT") cores. This LCT configuration ensures that, as the push layer expands longitudinally within the compartment formed by the semipermeable membrane, the surface area of the push layer in contact with the semipermeable membrane is increased more than when other configurations are used.

In a preferred embodiment, sufficient activity in the push layer is achieved by use of a relatively large concentration (at least about 35%) of osmotically effective solute, or osmagent, such as sodium chloride. Consequently, the size of the push layer is relatively large and may be slightly larger than the first component layer containing the drug and excipients. In addition, for certain embodiments, sorbitol was found to be a useful excipient in the first component layer. It has been surprisingly discovered that the combination of features described above, including the LCT core configuration, the relatively high percent of osmagent and, in some exemplary embodiments, the use of sorbitol as an excipient provides the desired ascending release rate over an extended time period from bi-layer oral osmotic dosage forms. Exemplary embodiments of such bi-layer osmotic dosage forms are detailed below in Examples 1-3.

An embodiment of a bi-layer oral osmotic dosage form **15** is shown in cross-section in FIG. 1. The components are not drawn to scale. The bi-layer LCT core comprises a first component layer **21**, containing drug and selected excipients, and a second push layer **29**, containing at least one fluid-expandable osmopolymer and optionally containing at least one osmagent along with selected excipients. Suitable excipients are known in the art and include diluents, carriers, binders, fillers and processing aids. A semipermeable membrane **57** surrounds the bi-layer tablet core to form a compartment and a suitably sized orifice **55** is formed through the semipermeable membrane and into the first component layer **21** to permit drug formulation to be released from within the compartment. As illustrated, the orifice **55** is preferably formed in the narrow end of the

dosage form comprising the first component layer. In operation, through cooperation of the bi-layer osmotic dosage form components, drug is released from the first drug-containing layer at an ascending release rate for an extended time period. Although not shown in FIG. 1, an immediate-release dose of a drug may be provided by applying a drug-containing overcoat to a bi-layer dosage form, if desired, as described elsewhere herein.

In addition to the above-described bi-layer osmotic dosage forms, it has been surprisingly discovered that oral osmotic dosage forms exhibiting an ascending drug release rate for an extended time period can also be achieved with a novel tri-layer tablet core surrounded by a semipermeable membrane and having suitable exit means for releasing drug formulation through the semipermeable membrane. The novel tri-layer tablet core has a first drug-containing layer, a second drug-containing layer and a third push layer. In operation, through the cooperation of the dosage form components, drug is successively released, in a sustained and controlled manner, from the first drug-containing layer and then from the second drug-containing layer such that an ascending release rate over an extended time period is achieved.

It has been discovered that a drug concentration gradient between the first and second drug-containing layers of the tri-layer core facilitates the achievement of an ascending drug release rate for an extended time period from the tri-layer osmotic dosage form. Consequently, the other excipients in the drug-containing layers may be more flexibly varied and adjusted for other purposes such as manufacturing convenience and pharmaceutical elegance. For example, the tri-layer osmotic dosage forms preferably avoid the use of sorbitol as an excipient. This provides manufacturing efficiency and product shelf-life advantages since sorbitol is very hygroscopic and attracts moisture during storage which can pose difficulties in handling and manufacturing as well as longer-term stability concerns. In addition, sufficient activity in the push layer may be achieved with the use of a relatively lower concentration (less than about 25%) of osmotically effective solute such that the size of the push layer can be smaller relative to the size of the two drug-containing layers. Preferably, the push layer is smaller than the combined size of the first and second drug-containing layers. An advantage to a smaller-sized push layer is that larger doses of drug, if desired, can be accommodated without the overall size of the dosage form becoming so large as to engender manufacturing challenges and/or to become unpalatable to patients.

In a presently preferred embodiment, the hydration rate of the tri-layer osmotic dosage form is improved with the inclusion of a flux-enhancing agent in the semipermeable membrane. In addition, it is preferred to use the longitudinally compressed tablet ("LCT") core configuration, as described above, for the tri-layer osmotic dosage forms to also enhance hydration. In a presently preferred embodiment, the combination of features including the LCT tri-layer core configuration, a suitable drug concentration gradient between the first and second component layers, the osmotic properties of the component layers and the fluid flux properties of the semipermeable membrane achieves the desired ascending rate of drug release over an extended time period. Advantageously, such preferred embodiments exhibit consistent and reliable operation and can be efficiently manufactured on a large-scale basis.

A preferred embodiment of a tri-layer oral osmotic dosage form additionally comprising an immediate-release dose of drug applied as an overcoat and an aesthetic overcoat **14** is

13

shown in cross-section in FIG. 2. The tri-layer LCT core comprises a first component layer 20, containing a selected drug in a pharmaceutically acceptable form along with selected excipients; a second component layer 18, containing a higher concentration of drug along with selected excipients; and a third push layer 28, containing at least one osmopolymer and optionally containing at least one osmagent along with selected excipients. A semipermeable membrane 56 surrounds the tri-layer tablet core to form a compartment and a suitably sized orifice 54 is formed through the semipermeable membrane and into the first component layer to permit drug formulation to be released from within the compartment. As illustrated, the orifice 54 is preferably formed in the narrow end of the dosage form comprising the first component layer. In operation, through cooperation of the tri-layer osmotic dosage form components, drug is successively released, in a sustained and controlled manner, from the first drug-containing layer and then from the second drug-containing layer at an ascending release rate for an extended time period.

As shown in FIG. 2, the preferred embodiment further comprises an immediate-release dose of drug contained within an overcoat 60 applied onto the surface of the tri-layer osmotic dosage form. The drug is mixed with suitable excipients such as, for example, hydroxypropylmethylcellulose, to prepare a solution for coating onto the surface of the semipermeable membrane of the tri-layer osmotic dosage form that will rapidly dissolve and release drug following administration.

As shown in FIG. 2, it is also preferred to provide an optional aesthetic overcoat 62 applied onto the surface of the drug-containing overcoat 60. As known in the art, such aesthetic overcoats provide advantages including taste-masking, improved appearance and "glidability" for facilitating swallowing and further processing steps such as printing, packaging, etc. Exemplary embodiments of tri-layer osmotic dosage forms that exhibit a substantially ascending release rate over an extended time period are detailed below in Examples 4-6 and Examples 8 and 9.

The continued maintenance of therapeutic effectiveness over a prolonged therapy period by the administration of the oral osmotic dosage forms that exhibit an ascending release rate over an extended time period of the present invention has been demonstrated. An exemplification is described below in Example 7. In particular, it has been discovered that such osmotic dosage forms containing methylphenidate can be used to provide effective once-a-day therapy; for ADHD. This discovery represents an important improvement in drug therapy for ADHD by eliminating the need for multiple daily doses of methylphenidate yet providing therapeutic efficacy throughout the day that compares to the therapeutic efficacy provided by multiple doses of immediate release methylphenidate.

The following examples are illustrative of the present invention, and the is examples should not be considered as limiting the scope of the invention in any way, as these examples, and other equivalents thereof, will become apparent to those versed in the art in the light of the present disclosure and the accompanying claims.

EXAMPLE 1

Bi-layer oral osmotic dosage forms were made in accord with conventional manufacturing processes known in the art and disclosed in detail in copending U.S. application Ser. No. 967,606, filed Nov. 10, 1997, of which the present application is a continuation-in-part application. Briefly, a

14

first component layer, containing methylphenidate hydrochloride and selected excipients, and a second push layer, containing suitable osmopolymers, 40% by weight of an osmagent and selected excipients, were separately prepared by granulation methods. Next, the first component layer and the second push layer granulation preparations were longitudinally compressed together to form bi-layer LCT cores. A selected semipermeable membrane was then coated around the bi-layer LCT cores and a suitable 30 mil orifice for drug release was formed therethrough and into the first component layer.

Each dosage form as prepared comprised:

First component layer	
14.08 mg	methylphenidate hydrochloride
90.26 mg	poly(ethylene)oxide (200,000 number-average molecular weight)
5.5 mg	poly(vinylpyrrolidone) (40,000 number-average molecular weight)
0.11 mg	magnesium stearate
0.555 mg	butylated hydroxy toluene
Second push layer	
71.032 mg	poly(ethylene)oxide (7,000,000 number-average molecular weight)
52.8 mg	sodium chloride
6.6 mg	poly(vinylpyrrolidone) (40,000 number-average molecular weight)
1.32 mg	red ferric oxide
0.132 mg	magnesium stearate
0.555 mg	butylated hydroxy toluene
Semipermeable Membrane	
15.3 mg	cellulose acetate (39.8% acetyl content)
1.7 mg	poly(ethylene glycol) (3350 number-average molecular weight)

The periodic release rates from the dosage form were determined hourly for ten hours using in vitro dissolution testing. A residual quantity of drug of 0.72 mg remained in the dosage form. The results are shown in Table 1 along with an indication of whether an ascending release rate occurred.

TABLE 1

Time (hours)	Quantity of drug released (mg)	Ascending Release Rate Occurrence
1	0.22	YES
2	1.45	YES
3	1.72	YES
4	1.84	YES
5	2.05	YES
6	2.21	YES
7	2.13	NO
8	1.26	NO
9	0.39	NO
10	0.09	NO

As seen from Table 1, drug was released from the dosage forms at an ascending rate for an extended time period, i.e., more than 90% of the drug was released by t=8 hours and ascending release rates occurred through t=6 hours, an extended period of time well beyond the mid-point of the T₉₀.

EXAMPLE 2

Bi-layer oral osmotic dosage forms were made in accord with conventional manufacturing processes known in the art and disclosed in detail in copending U.S. application Ser.

15

No. 967,606, filed Nov. 10, 1997, of which the present application is a continuation-in-part application. Briefly, a first component layer, containing methylphenidate hydrochloride, sorbitol and selected excipients, and a second push layer, containing suitable osmopolymers, 40% by weight of an osmagent and selected excipients, were separately prepared by granulation methods. Next, the first component layer and the second push layer granulation preparations were longitudinally compressed together to form bi-layer LCT cores. A selected semipermeable membrane was then coated around the bi-layer LCT cores and a suitable 30 mil orifice for drug release was formed there-through.

Each dosage form as prepared comprised:

<u>First component layer (110 mg)</u>	
12.8%	methylphenidate hydrochloride
54.75%	poly(ethylene)oxide (200,000 number-average molecular weight)
25.4%	sorbitol
5%	hydroxypropylmethylcellulose (11,200 number-average molecular weight)
2%	magnesium stearate
0.05%	butylated hydroxy toluene
<u>Second push layer (132 mg)</u>	
53.85%	poly(ethylene)oxide (7,000,000 number-average molecular weight)
40%	sodium chloride
5%	hydroxypropylmethylcellulose (11,200 number-average molecular weight)
1%	red ferric oxide
0.1%	magnesium stearate
0.05%	butylated hydroxy toluene
<u>Semipermeable Membrane (42 mg)</u>	
47.5%	cellulose acetate (39.8% acetyl content)
47.5%	cellulose acetate (32% acetyl content)
5%	poly(ethylene glycol) (3350 number-average molecular weight)

The periodic release rates from the dosage form were determined hourly for twelve hours. No residual quantity of drug remained in the dosage form. The results are shown in Table 2 along with an indication of the occurrences of an ascending release rate.

TABLE 2

Time (hours)	Quantity of drug released (mg)	Ascending Release Rate Occurrence
1	0.13	YES
2	1.16	YES
3	1.53	YES
4	1.61	YES
5	1.75	YES
6	1.79	YES
7	2.13	YES
8	2.18	YES
9	1.07	NO
10	0.43	NO
11	0.17	NO
12	0.13	NO

As seen from Table 2, more than 90% of the drug was released by t hours and ascending release rates occurred through t=8 hours, an extended time period well beyond the mid-point of the T₉₀.

EXAMPLE 3

Bi-layer oral osmotic dosage forms additionally comprising an immediate-release dose of drug applied as an over-

16

coat onto the semipermeable membrane were made in accord with conventional manufacturing processes known in the art and disclosed in detail in copending U.S. application Ser. No. 967,606, filed Nov. 10, 1997, of which the present application is a continuation-in-part application. Briefly, a first component layer, containing methylphenidate hydrochloride, sorbitol and selected excipients, and a second push layer, containing suitable osmopolymers, 39.8% by weight of an osmagent and selected excipients, were separately prepared by granulation methods. Next, the first component layer and the second push layer granulation preparations were longitudinally compressed together to form bi-layer LCT cores. A selected semipermeable membrane was then coated around the bi-layer LCT cores and a suitable 30 mil orifice for drug release was formed there-through. A drug-containing overcoat mixture was prepared and coated onto the semipermeable membrane of the osmotic dosage form. Optionally, a taste-masking overcoat is also applied.

Each osmotic bi-layer dosage form as prepared comprised:

<u>First component layer</u>	
14 mg	methylphenidate hydrochloride
61 mg	poly(ethylene)oxide (2,000,000 number-average molecular weight)
27.5 mg	sorbitol
5.5 mg	polyvinylpyrrolidone
2.2 mg	magnesium stearate
0.055 mg	butylated hydroxy toluene
<u>Second push layer</u>	
72 mg	poly(ethylene)oxide (7,000,000 number-average molecular weight)
53 mg	sodium chloride
6.6 mg	polyvinylpyrrolidone
1.3 mg	red ferric oxide
0.132 mg	magnesium stearate
0.066 mg	butylated hydroxy toluene
<u>Semipermeable Membrane</u>	
20 mg	cellulose acetate (39.8% acetyl content)
20 mg	cellulose acetate (32% acetyl content)
2 mg	poly(ethylene glycol) (4000 number-average molecular weight)

An immediate-release drug-containing overcoat comprising 60% hydroxypropylmethylcellulose and 40% methylphenidate hydrochloride is prepared and a final solution of 10 mg (i.e., containing 4 mg of methylphenidate salt) is coated onto the semipermeable membrane of the osmotic dosage form.

The periodic release rates from the drug overcoat and the osmotic dosage form were determined at 30 minutes, 1 hour and then hourly for the next nine hours. The 4 mg of methylphenidate contained within the drug overcoat was released within the first 30 minutes and the periodic release rate shown at t=1 hour of 0.41 mg constitutes drug released from the bi-layer osmotic dosage form during the second 30-minute interval. No residual quantity of drug remained in the dosage form. The hourly results are shown in Table 3 along with an indication of the occurrences of an ascending release rate.

TABLE 3

Time (hours)	Quantity of drug released (mg)	Ascending Release Rate Occurrence
1	0.41	YES
2	1.05	YES
3	1.49	YES
4	1.57	YES
5	1.71	YES
6	1.75	YES
7	2.09	YES
8	2.14	YES
9	1.32	NO
10	0.48	NO

As seen from Table 3, exclusive of the immediate-release drug overcoat, more than 90% of the drug was released by t=9 hours and ascending release rates occurred through t=8 hours, an extended period of time well beyond the mid-point of the T₉₀.

EXAMPLE 4

Tri-layer oral osmotic dosage forms were made in accord with conventional manufacturing processes known in the art and disclosed in detail in copending U.S. application Ser. No. 937,336, filed Aug. 19, 1997, of which the present application is a continuation-in-part application. Briefly, a first component layer, containing pseudoephedrine hydrochloride and selected excipients, a second component layer, containing a higher concentration of pseudoephedrine hydrochloride and selected excipients, and a third push layer, containing suitable osmopolymers, an osmagent and selected excipients, were separately prepared by granulation methods. Next, the first component layer, second component layer and the third push layer granulation preparations were longitudinally compressed together to form tri-layer LCT cores. A selected semipermeable membrane was then coated around the tri-layer LCT cores and a suitable 30 mil orifice for drug release was formed therethrough.

Each dosage form as prepared comprised:

First component layer	
4.4 mg	pseudoephedrine hydrochloride
15.3 mg	poly(ethylene)oxide (300,000 number-average molecular weight)
1.1 mg	hydroxypropylmethylcellulose (9,200 number-average molecular weight)
1.1 mg	polyoxyethylene 40 stearate
0.11 mg	magnesium stearate
Second component layer	
13.5 mg	pseudoephedrine hydrochloride
2.59 mg	poly(ethylene)oxide (300,000 number-average molecular weight)
0.9 mg	hydroxypropylmethylcellulose (9,200 number-average molecular weight)
0.9 mg	polyoxyethylene 40 stearate
0.018 mg	red ferric oxide
0.09 mg	magnesium stearate
Third push layer	
22.2 mg	poly(ethylene)oxide (7,000,000 number-average molecular weight)
12 mg	sodium chloride
2 mg	hydroxypropylmethylcellulose (9,200 number-average molecular weight)
2 mg	polyoxyethylene 40 stearate

-continued

5	1.2 mg	cross-linked acrylic acid polymer
	0.4 mg	red ferric oxide
	0.2 mg	magnesium stearate
		<u>Semipermeable Membrane</u>
10	11.4 mg	cellulose acetate (39.8% acetyl content)
	0.6 mg	polyethylene glycol (3350 average number molecular weight)

The periodic release rates from the osmotic dosage form were determined hourly for 7 hours and results are shown in Table 4 along with an indication of the occurrences: of an ascending release rate.

TABLE 4

Time (hours)	Quantity of drug released (mg)	Ascending Release Rate Occurrence
1	0.13	YES
2	0.65	YES
3	2.2	YES
4	2.78	YES
5	3.24	YES
6	3.14	YES
7	3.43	YES

As seen from Table 4, about 87% of drug was released during the first 7 hours and ascending release rates were achieved throughout this period.

EXAMPLE 5

Tri-layer oral osmotic dosage forms having a drug concentration gradient wherein the drug concentration was greater in the second component layer than the first component layer and also having viscosity gradients wherein the viscosity of the first component layer was less than the viscosity of the second component layer and the viscosity of the second component layer was lower than the viscosity of the third push layer were made in accord with conventional manufacturing processes known in the art and disclosed in detail in copending U.S. application Ser. No. 937,336, filed Aug. 19, 1997, of which the present application is a continuation-in-part application.

Each dosage form as prepared comprised:

First component layer (350 mg)	
8.6%	nicardipine
54.8%	sorbitol
36.8%	poly(ethylene)oxide (200,000 number-average molecular weight)
Second component layer (120 mg)	
45%	nicardipine
50%	poly(ethylene)oxide (300,000 number-average molecular weight)
5%	hydroxypropylmethylcellulose (9,200 number-average molecular weight)
Third push layer (350 mg)	
68.75%	poly(ethylene)oxide (7,000,000 number-average molecular weight)
20%	sodium chloride
5%	hydroxypropylmethylcellulose (9,200 number-average molecular weight)

-continued

5%	cross-linked acrylic acid polymer
1%	ferric oxide
0.25%	magnesium stearate
<u>Semipermeable Membrane (43.5 mg)</u>	
95%	cellulose acetate (39.8% acetyl content)
5%	polyethylene glycol (3350 average number molecular weight)

The dosage forms had 25 mil exit orifices formed through the semipermeable membrane to permit release of drug formulation from within the compartment. An ascending release rate for an extended time period of about 16 hours was achieved with the dosage forms of Example 5.

EXAMPLE 6

Preferred embodiments of the tri-layer osmotic dosage forms of the present invention additionally comprising an immediate-release dose of drug applied as an overcoat, as shown in FIG. 2, were prepared in accord with conventional osmotic tablet manufacturing processes.

The first component layer contained the following (by weight percent): 9.40% methylphenidate hydrochloride, 83.71% polyethylene oxide (Polyox N-80 brand product of Union Carbide, Danbury, Conn.), 5% polyvinylpyrrolidone (Kolidon 29-32 product of BASF Corp., Mt. Olive, N.J.); 1.34% succinic acid; 0.5% stearic acid; and 0.05% butylated hydroxy toluene.

The second component layer contained the following (by weight percent): 13.65% methylphenidate hydrochloride, 78.80% polyethylene oxide (Polyox N80 brand product of Union Carbide, Danbury, Conn.), 5% polyvinylpyrrolidone (Kolidon 29-32 product of BASF Corp., Mt. Olive, N.J.); 1.95% succinic acid; 0.5% stearic acid; 0.05% butylated hydroxy toluene; and 0.05% yellow ferric oxide, as coloring agent.

The third push layer contained the following (by weight percent): 73.7% high molecular weight polyethylene oxide (Polyox 303 brand product of Union Carbide, Danbury, Conn.), 20% sodium chloride; 5% polyvinylpyrrolidone (Kolidon 29-32 brand product of BASF Corp., Mt. Olive, N.J.); 0.25% stearic acid; 0.05% butylated hydroxy toluene; and 1% green ferric oxide, as coloring agent.

Each of the first component layer, second component layer and third push layer were separately prepared into granulated compositions in a fluid bed granulator. The granulated compositions were then compressed sequentially and longitudinally on a rotary tablet press to produce the tri-layer LCT cores. For each dosage form, 40 mg of the first component layer granulation and 75 mg of the second component layer granulation were first sequentially filled and tamped at 100 newtons into the die. Then, 90 mg of the third push layer granulation to the die was added to the die and the final compression was performed at 1500 newtons.

The composition of the semipermeable membrane was 83% by weight cellulose acetate (CA 398-10, having an acetyl content of 39.8%, product of Eastman Chemical, Kingsport, Tenn.) and 17% by weight copolymer of ethylene and propylene oxide (Poloxamer 188 brand product of BASF Corp., Mt. Olive, N.J., added as a flux-enhancer. The two ingredients were dissolved in a blend of 99.5% acetone and 0.5% water to form a 5% solids solution. In a pan Coater, the solution was then sprayed onto the tri-layer LCT cores to a weight of 25.7 mg and a thickness of 4-5 mil.

After the semipermeable membrane had been applied to form a compartment containing the tri-layer LCT cores, a 0.76 mm (40 mil) orifice was drilled through the semipermeable membrane at the narrow end of the compartment proximate to the first component layer to thereby form the preferred tri-layer osmotic dosage forms, each containing 14 mg of methylphenidate. Each dosage form was approximately 12 mm long with an approximate diameter of 5.3 mm.

The drug overcoat for providing an immediate-release initial dose of drug contains approximately 30% by weight methylphenidate hydrochloride, approximately 70% by weight hydroxypropylmethylcellulose (Methocel E3 brand name product of Dow Chemical Co., Midland, Mich.), and a trace amount of phosphoric acid (i.e., 20 ml of phosphoric acid added to 87 kg of drug in solution). An aqueous coating solution is prepared by dissolving and mixing the ingredients in water to form a solution with a 10% solids composition. In a pan coater, the solution was then sprayed onto the semipermeable membranes of the tri-layer osmotic dosage forms to a weight of about 14.0 mg comprising an immediate-release dose of methylphenidate of about 4 mg.

The final aesthetic overcoat composition weighed 16.9 mg and contained an underlayer of Opadry II, yellow (brand name product of Colorcon, West Point, Pa. and an overlayer of Opadry, clear, with a trace amount of camauaba wax, a glidant, prepared and applied as follows: first, Opadry II (10%) is suspended in water (90%) and sprayed onto the drug-overcoated dosage forms; next, clear Opadry (5%) is suspended in water (95%) and sprayed onto the drug- and Opadry II-overcoated dosage forms; finally, the dosage forms are tumbled in the coater with the carnauba wax for ten minutes to allow about 100 ppm of wax to be uniformly distributed onto the clear Opadry overcoat.

Many pharmaceutical dosage forms utilize drug in salt form such as the hydrochloride salt of methylphenidate utilized herein. Such salt forms of drugs prepared in aqueous solution, however, are prone to degradation and, thus, often have stability and shelf-life problems. It has been discovered that the addition of an appropriate pH-adjusting agent to the aqueous solution decreases undesired degradation and improves the stability of the product. In particular, in preferred embodiments tri-layer osmotic dosage forms comprising methylphenidate hydrochloride, it has been discovered that degradation of the drug ingredient can be minimized by the addition of suitable antidegradation agents, i.e., succinic acid in the first and second component layers and phosphoric acid in the drug overcoat. Other suitable antidegradation agents include compounds that dissolve in an aqueous medium are pharmaceutically acceptable, i.e., nontoxic and suitable for oral administration to humans, and that exhibit sufficient pH-adjusting ability, i.e., have a pH no greater than 4 and preferably of 3 or below. Additional examples include potassium phosphate, sodium phosphate, fumaric acid, citric acid, tartaric acid, malic acid, hydrochloric acid, aspartic acid, glutamic acid, oxalic acid, lactic acid, malonic acid, glyceric acid and ascorbic acid.

Periodic release rates for twenty-four sample dosage forms prepared as described were determined hourly for 12 hours and are presented in graph form in FIG. 3. The mean quantities released each hour are shown in Table 5 along with an indication of the occurrences of an ascending release rate. It is noted that the entire 4 mg immediate-release dose was essentially released within the first hour and this quantity is disregarded with respect to the determination that an ascending release rate occurred at t=2 hours, i.e., the mean quantity at t=2 hours was compared to the mean quantity at t=1 hours less 4 mg representing the immediate-release dose.

TABLE 5

Time (hours)	Quantity of drug released (mg)	Ascending Release Rate Occurrence
1	4.098	YES
2	1.138	YES
3	1.650	YES
4	1.993	YES
5	2.043	YES
6	2.099	YES
7	1.966	NO
8	1.763	NO
9	0.428	NO
10	0.174	NO
11	0.084	NO
12	0.061	NO

As seen from Table 5, exclusive of the immediate-release drug overcoat, more than 90% of the drug was released by t=8 hours and ascending release rates occurred through t=6 hours, an extended period of time well beyond the mid-point of the T₉₀.

EXAMPLE 7

Therapeutic effectiveness of single doses of tri-layer osmotic dosage forms containing 14 mg of methylphenidate and additionally comprising an immediate-release drug overcoat containing 4 mg of methylphenidate was studied and compared to multiple doses of immediate-release methylphenidate. Safety and therapeutic efficacy parameters were evaluated for a 12-hour period in the same subjects treated with the following regimens on different days: the experimental regimen wherein the tri-layer osmotic dosage form was administered once at t=0 hours and the standard regimen wherein immediate-release methylphenidate (Ritalin®) was administered three times, at t=0 hours, t=4 hours, and t=8 hours. Because the subjects were current methylphenidate users, the doses of methylphenidate administered during each regimen varied somewhat to match as closely as possible the "usual dose" each subject was routinely administered. For comparative purposes, the actual doses were normalized to a single 18 mg dose of the tri-layer osmotic dosage and to: 15 mg of Ritalin® administered as three 5 mg doses.

Plasma drug concentrations were determined in all subjects at the same times during the study periods for each regimen. The selected times corresponded to the time just prior to, and 1.5 hours and 2.5 hours following, administration of the first two doses of immediate-release methylphenidate (i.e., at t=0 hours, t=1.5 hours, t=2.5 hours, t=4 hours, t=5.5 hours, t=6.5 hours), and just prior to, and 1.5 hours and 3.5 hours following, administration of the third dose (i.e., at t=8 hours, t=9.5 hours and t=11.5 hours).

In FIG. 4, plasma drug concentrations obtained from one group of study participants (n=16) while treated with the experimental regimen represented by open diamonds) and while treated with the standard regimen represented by closed circles) are shown in graph form. A comparison of FIG. 3 and 4 demonstrates a correlation between the in vitro release rates through about t=8 hours and the in vivo plasma drug concentrations through about t=9.5 hours.

As shown in FIG. 4, the plasma drug concentration following each administration of an immediate-release dose rises relatively rapidly and then declines at a generally characteristic rate until the next dose is administered. The

plasma drug concentration following administration of the tri-layer osmotic dosage form also exhibits an initial relatively rapid rise due largely to release of drug from the immediate-release drug overcoat. Subsequently, however, the plasma drug concentration does not decline but continues to substantially ascend (save for a slight "dip" between t=5.5 hours and t=6.5 hours) through a time period of 9.5 hours. Particularly striking is the difference during the time periods within about 1 hour before and about 1.5 hours following administration of the second and the third immediate-release dose. With the standard regimen, during these periods, the plasma drug concentration declines to a trough concentration and then rises again to a peak concentration. With the experimental regimen, during these same time periods, the plasma drug concentration is substantially smoothly ascending and exhibits no peaks and troughs.

Safety and therapeutic parameters, including behavioral, attentional and cognitive functions, were assessed hourly during the first three hours and the last three hours of the study period and at two-hour intervals in between. The clinical effectiveness of the experimental regimen was closely comparable to the clinical effectiveness of the standard regimen throughout the twelve-hour study period. An effective once-a-day therapy for ADHD provides many advantages and offers a significant improvement in drug therapy by eliminating the need for multiple daily doses of methylphenidate while providing continued therapeutic efficacy throughout the day.

EXAMPLE 8

Tri-layer oral osmotic dosage forms were made in accord with the manufacturing processes of Example 6 but comprising twice as much methylphenidate, i.e., a total of 28 mg of methylphenidate contained within the first and second component layers and 8 mg of methylphenidate in the drug overcoat. All of the remaining ingredients are also doubled so that the weight percents are the same as in Example 6. The third push layer is also doubled. The semipermeable membrane had the same composition as in Example 6 but was applied to a weight of about 34 mg.

These dosage forms exhibit release of 36 mg of methylphenidate with about 8 mg released immediately and the remaining 28 mg released at an ascending release rate over an extended time period.

EXAMPLE 9

Tri-layer oral osmotic dosage forms were made in accord with the manufacturing processes of Example 6 but comprising a total of 42 mg of methylphenidate contained within the first and second component layers and 12 mg of methylphenidate in the drug overcoat. The first component layer contained the following (by weight percent): 11.5% methylphenidate hydrochloride, 81.6% polyethylene oxide (Polyox N-80 brand product of Union Carbide, Danbury, Conn.), 5% polyvinylpyrrolidone (Kolidon 29-32 product of BASF Corp., Mt. Olive, N.J.); 1.3% succinic acid; 0.5% stearic acid; 0.05% butylated hydroxy toluene; and 0.05% yellow ferric oxide, as coloring agent. The second component layer contained the following (by weight percent): 19.8% methylphenidate hydrochloride, 72.7% polyethylene oxide (Polyox N-80 brand product of Union Carbide, Danbury, Conn.), 5% polyvinylpyrrolidone (Kolidon 29-32 product of BASF Corp., Mt. Olive, N.J.); 1.95% succinic acid; 0.5% stearic acid; and 0.05% butylated hydroxy toluene. The third push layer is doubled from Example 6 and the semipermeable membrane had the same composition as in Example 6 but was applied to a weight of about 34 mg.

These dosage forms exhibit release of 54 mg of methylphenidate with about 12 mg released immediately and the remaining 42 mg released at an ascending release rate over an extended time period.

While there has been described and pointed out features and advantages of the invention, as applied to present embodiments, those skilled in the art will appreciate that various modifications, changes, additions, and omissions in the descriptions within the specification can be made without departing from the spirit of the invention.

We claim:

1. A method for treating ADD or ADHD comprising administering a dosage form comprising methylphenidate that provides a release of methylphenidate at an ascending release rate over an extended period of time.

2. The method of claim 1 wherein said administration results in a substantially ascending methylphenidate plasma drug concentration over a time period of about 4 hours following said administration.

3. The method of claim 1 wherein said administration results in a substantially ascending methylphenidate plasma drug concentration over a time period of about 4 to about 5.5 hours following said administration.

4. The method of claim 1 wherein said administration results in a substantially ascending methylphenidate plasma drug concentration over a time period of about 4 to about 8 hours following said administration.

5. The method of claim 1 wherein said administration results in a substantially ascending methylphenidate plasma drug concentration over a time period of about 4 to about 9.5 hours following said administration.

6. The method of claim 1 wherein said administration results in a substantially ascending methylphenidate plasma drug concentration over a time period of about 5.5 hours following said administration.

7. The method of claim 1 wherein said administration results in a substantially ascending methylphenidate plasma drug concentration over a time period of about 8 hours following said administration.

8. The method of claim 1 wherein said administration results in a substantially ascending methylphenidate plasma drug concentration over a time period of about 9.5 hours following said administration.

* * * * *

UNITED STATES PATENT AND TRADEMARK OFFICE
Certificate

Patent No. 6,919,373 B1

Patented: July 19, 2005

On petition requesting issuance of a certificate for correction of inventorship pursuant to 35 U.S.C. 256, it has been found that the above identified patent, through error and without any deceptive intent, improperly sets forth the inventorship.

Accordingly, it is hereby certified that the correct inventorship of this patent is: Suneel K. Gupta, Sunnyvale, CA (US); Diane R. Guinta, Palo Alto, CA (US); Carol A. Christopher, Belmont, CA (US); Samuel R. Saks, Burlingame, CA (US); and Lawrence G. Hamel, Mountain View, CA (US).

Signed and Sealed this Twenty-ninth Day of April 2007.

WILLIAM R. DIXON, Jr.
Technology Center 1600