



US005645081A

United States Patent [19]

[11] Patent Number: **5,645,081**

Argenta et al.

[45] Date of Patent: ***Jul. 8, 1997**

[54] METHOD OF TREATING TISSUE DAMAGE AND APPARATUS FOR SAME

[75] Inventors: **Louis C. Argenta**, Winston-Salem;
Michael J. Morykwas, Pfafftown, both
of N.C.

[73] Assignee: **Wake Forest University**,
Winston-Salem, N.C.

[*] Notice: The portion of the term of this patent
subsequent to Mar. 9, 2013, has been
disclaimed.

[21] Appl. No.: **792,001**

[22] Filed: **Nov. 14, 1991**

[51] Int. Cl.⁶ **A61B 19/00**

[52] U.S. Cl. **128/897; 602/42**

[58] Field of Search **128/897-8; 602/42-53**

[56] References Cited

U.S. PATENT DOCUMENTS

Re. 29,319	7/1977	Nordby et al. .
765,746	7/1904	Miner .
843,674	2/1907	Funk .
1,355,679	10/1920	McConnell .
1,355,846	10/1920	Rannells .
1,385,346	7/1921	Taylor .
2,232,254	2/1941	Morgan .
2,338,339	1/1944	LaMere .
2,969,057	1/1961	Simmons .
3,026,526	3/1962	Montrose .
3,026,874	3/1962	Stevens .
3,367,332	2/1968	Groves .
3,478,736	11/1969	Roberts et al. .
3,481,326	12/1969	Schamblin .
3,486,504	12/1969	Austin, Jr. .
3,610,238	10/1971	Rich, Jr. .
3,682,180	8/1972	McFarlane .
3,826,254	7/1974	Mellor .
3,874,387	4/1975	Barbieri .
3,896,810	7/1975	Akiyama .
3,908,664	9/1975	Loseff .

(List continued on next page.)

FOREIGN PATENT DOCUMENTS

561757	9/1932	Germany .
2809828	9/1978	Germany .
4111122	4/1993	Germany .
641061	8/1950	United Kingdom .
1273342	5/1972	United Kingdom .
9011795	10/1990	WIPO A61M 27/00
9100718	1/1991	WIPO .
WO9116030	10/1991	WIPO .
WO9219313	11/1992	WIPO .

OTHER PUBLICATIONS

Rastgeldi, S.: I. Pressure Treatment of Peripheral Vascular Diseases. II. Intermittent Pressure Treatment of Peripheral Vascular Diseases. *Opuscula Medica, Suppl. XXVII*, 1972.

Junod, "Hyperemia by Suction Apparatus", Chapter VIII. Saunders, J.W., *The Lancet*, pp. 1286-1287, Jun. 28, 1952, "Negative-Pressure Device for Controlled Hypotension During Surgical Operations".

Landis et al., Robinette Foundation of the Hospital of the University of Pennsylvania, "The Effects of Alternate Suction and Pressure on Blood Flow to the Lower Extremities".

Hargens et al., Space Physiology Laboratory, Life Science Division, NASA Ames Research Center, "Control of Circulatory Functions in Altered Gravitational Fields".

Wolthuis et al., *Physiological Reviews*, 54: 566-595, Jul. 1974, "Physiological Effects of Locally Applied Reduced Pressure in Man".

(List continued on next page.)

Primary Examiner—Angela D. Sykes

Assistant Examiner—John P. Lacyk

Attorney, Agent, or Firm—Dann Dorfman Herrell and Skillman

[57] ABSTRACT

The invention disclosed is a method of treating tissue damage comprising applying a negative pressure to a wound sufficient in time and magnitude to promote tissue migration and thus facilitate closure of the wound. The method is applicable to wounds, burns, infected wounds, and live tissue attachments. Configurations of apparatus for carrying out the method are also disclosed.

82 Claims, 1 Drawing Sheet

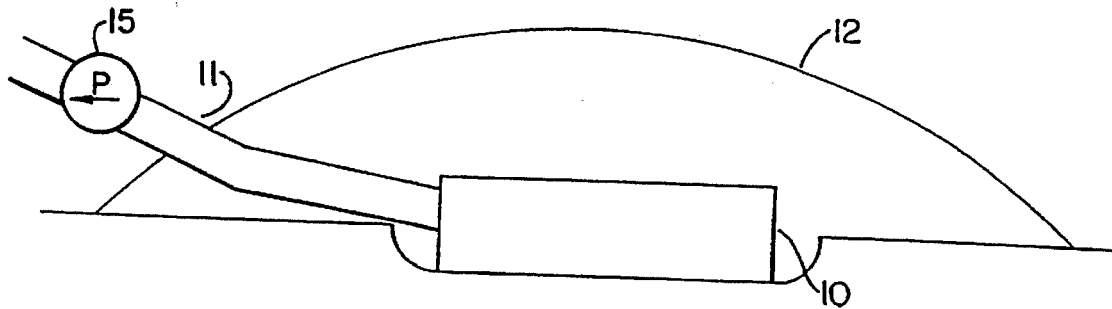

U.S. PATENT DOCUMENTS

3,954,105 5/1976 Nordby et al. .
 3,993,080 11/1976 Loseff .
 4,080,970 3/1978 Miller .
 4,112,947 9/1978 Nehring .
 4,149,541 4/1979 Gammons et al. .
 4,172,455 10/1979 Beaussant .
 4,224,945 9/1980 Cohen .
 4,250,882 2/1981 Adair .
 4,261,363 4/1981 Russo .
 4,275,721 6/1981 Olson .
 4,297,995 11/1981 Golub .
 4,373,519 2/1983 Errede .
 4,382,441 5/1983 Svedman .
 4,469,092 9/1984 Marshall et al. .
 4,525,166 6/1985 Leclerc .
 4,540,412 9/1985 Van Overloop .
 4,573,965 3/1986 Russo .
 4,608,041 8/1986 Nielsen .
 4,624,656 11/1986 Clark et al. .
 4,759,354 7/1988 Quarfoot .
 4,764,167 8/1988 Tu .
 4,765,316 8/1988 Marshall .
 4,778,456 10/1988 Lokken .
 4,820,265 4/1989 DeSatnick et al. .
 4,820,284 4/1989 Hauri .
 4,823,110 4/1989 Richard .
 4,836,192 6/1989 Abbate .
 4,906,233 3/1990 Moriuchi et al. .
 4,917,112 4/1990 Kalt .
 4,921,492 5/1990 Schultz et al. .
 4,941,882 7/1990 Ward et al. .
 4,953,565 9/1990 Tachibana et al. .
 4,969,880 11/1990 Zamierowski .
 4,969,881 11/1990 Viesturs .
 5,086,764 2/1992 Gilman .
 5,106,362 4/1992 Gilman .
 5,113,871 5/1992 Viljanto .
 5,149,331 9/1992 Ferdman .
 5,228,431 7/1993 Giarretto .

OTHER PUBLICATIONS

Viljanto et al., *Br. J. Surg.*, 63: 427-430, 1976, "Local hyperalimentation of open wounds".

Dillon, *Angiology—The Journal of Vascular Diseases*, pp. 47-55, Jan. 1986, "Treatment of Resistant Venous Stasis Ulcers and Dermatitis with the End-Diastolid Pneumatic Compression Boot".

Lundvall et al., *Acta Physiol Scand*, 136: 403-409, accepted Jan. 28, 1989, "Transmission of externally applied negative pressure to the underlying tissue. A study on the upper arm of man".

Klemp et al., *The Journal of Investigative Dermatology*, pp. 725-726 (1989), "Subcutaneous Blood Flow in Early Male Pattern Baldness".

A. Harle, *Z. Orthop.*, 127: 513-517 (1989), "Schwachstellen herkommlicher Drainagen".

Dunlop et al., *Br. J. Surg.*, 77: 562-563 (1990), "Vacuum drainage of groin wounds after vascular surgery: a controlled trial".

Maddin et al., *International Journal of Dermatology*, 29: 446-450 (1990), "The Biological Effects of a Pulsed Electrostatic Field with Specific Reference to Hair: Electrotrichogenesis".

Nakayama et al., *Ann. Plast. Surg.*, 26: 499-502 (1991), "A New Dressing Method for Free Skin Grafting in Hands".

Hargens et al., *Aviation, Space and Environmental Medicine*, pp. 934-937, Oct. 1991, "Lower Body Negative Pressure to Provide Load Bearing in Space".

Author unknown, *Science*, Sep. 1992, p. 42, "The Not-So-Bald-Truth".

Techno Takatsuki Co., Ltd., 8-16 Hatchonishimachi, Takatsuki City, Osaka, Japan, "HiBlow Air Pump".

Wells Johnson Company, 2045 N. Forbes Blvd., Suite 106, Tucson, AZ, "Suction Tips".

Industrial Equipment News, P.O. Box 1158, Skokie, IL 60076-9786, "Miscellaneous Equipment".

Letsou et al. "Stimulation of Adenylate Cyclase Activity in Cultured Endothelial Cells Subjected to Cyclic Stretch." *Cardiovascular Surgery* 3. Toronto. Sep. 1989. 634-639.

Bucalo et al. "Inhibition of Cell Proliferation by Chronic Wound Fluid." *Wound Repair and Regeneration*. Miami. 1993. 181-186.

Falanga, Vincent. "Growth Factors and Chronic Wounds: The Need to Understand the Microenvironment." *Journal of Dermatology*, vol. 19: 667-672. 1992.

Urschel et al. "The Effect of Mechanical Stress on Soft and Hard Tissue Repair; a Review." *British Journal of Plastic Surgery*. 41, 182-186. 1988.

Gogia, Prem P. "The Biology of Wound Healing." *Ostomy/Wound Management*. Nov.-Dec. 1992. pp. 12-20.

Wysocki et al. "Wound Fluid from Chronic Leg Ulcers Contains Elevated Levels of Metalloproteinases MMP-2 and MMP-9." *The Society for Investigative Dermatology, Inc.* Jul. 1993. 64-68.

Olenius et al. "Mitotic Activity in Expanded Human Skin." *Plastic and Reconstructive Surgery*. Feb. 1993. 213-215.

Aeros, "Moblvac II."

Aeros, Aeros Instruments, Inc. 1111 Lakeside Drive, Gurnee, IL 60031. Aug., 1993. "Care-E-Vac."

Emerson, Series 55. J.H. Emerson Co., 22 Cottage Park Ave., Cambridge, MA 02140. "Emerson Post-Operative Suction Pumps."

Emerson, J.H. Emerson Co., (address: same as above). "Emerson Transport Suction Unit."

Aeros, Aeros Instruments, Inc. 3411 Commercial Ave., Northbrook, IL 60062. Oct. 1988. Part No. 1504-02 7M. "Instavac Aspirator."

"Pleur-evac. Adult-Pediatric, Non-Metered." Code No.: A-4000. Control No.: F7961J.

Instruction Manual, Creative Medical Laboratories, Inc. P.O. Box 6347, Rochester, Minn. 55903. "TUGS" (Transportable Universal Gradient Suction).

Deknatel, Div. of Howmedica, Inc. Queens Village, NY 11429. "Pleur-evac."

Sparta Instrument Corp. 26602 Corporate Ave., Hayward, CA 94545. "Power Source Multi-Purpose Surgical Aspirator."

Wells Johnson Company, 2045 N. Forbes Blvd., Suite 106, Tucson, AZ. "Point 5 Aspirator."

Microtek Heritage, Inc. P.O. Box 2487, Columbus, MS 39704. "Wound-Evac ET."

Fleischmann, W. *Wund Forum Spezial*. IHW '94. "Vakuumsiegelung zur Behandlung von Problemwunden" (with English translation: Vacuum Sealing for Treatment of Problematical Wounds).

Fleischmann, W. *Acta Orthopaedica Belgica*. vol. 58, Suppl. I-1992 "Treatment of Bone and Soft Tissue Defects in Infected Nonunion."

Fleischmann, W. *Unfall Chirurg*. Springer-Variag 1993. "Vakuumversiegelung zur Behandlung des Weichteilschadens bei offenen Frakturen." (English abstract, no English translation.)

Valenta, A. *American Journal of Nursing*. Apr. 1994. "Using the Vacuum Dressing Alternative for Difficult Wounds."

Jeter, K.F. et al. (eds.), "Managing Draining Wounds and Fistulae: New and Established Methods," *Chronic Wound Care: Health Management Publications*, 1990, pp. 240-246.

Mulder, G.D. et al. (eds.), *Clinician's Pocket Guide to*

Chronic Wound Repair, (Spartanburg, SC: Wound Healing Publications), 1991, pp. 54-55.

Chariker, M.E. et al. (eds.), "Effective Management of Incisional and Cutaneous Fistulae with Closed Suction Wound Drainage," *Contemporary Surgery*, vol. 34, Jun. 1989, pp. 59-63.

M. Gosta Arturson, The Pathophysiology of Severe Thermal Injury, *JBCR*, 6(2):129-146 (Mar.-Apr. 1985).

R.A.F. Clark et al., *The Molecular and Cellular Biology of Wound Repair*, Chapter 1 (1988).

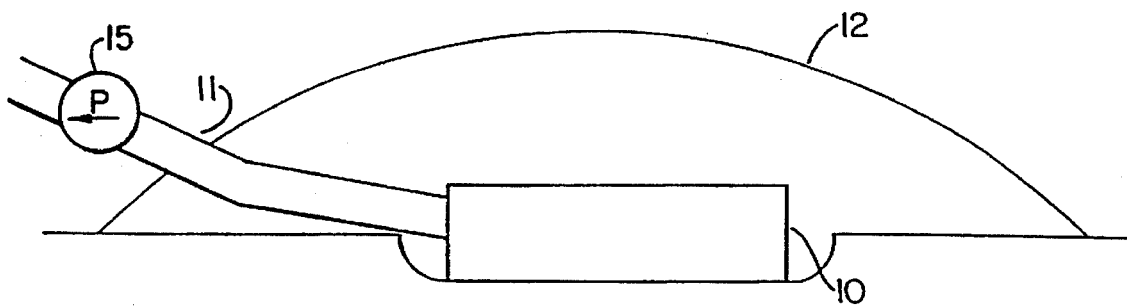

FIG. 1.

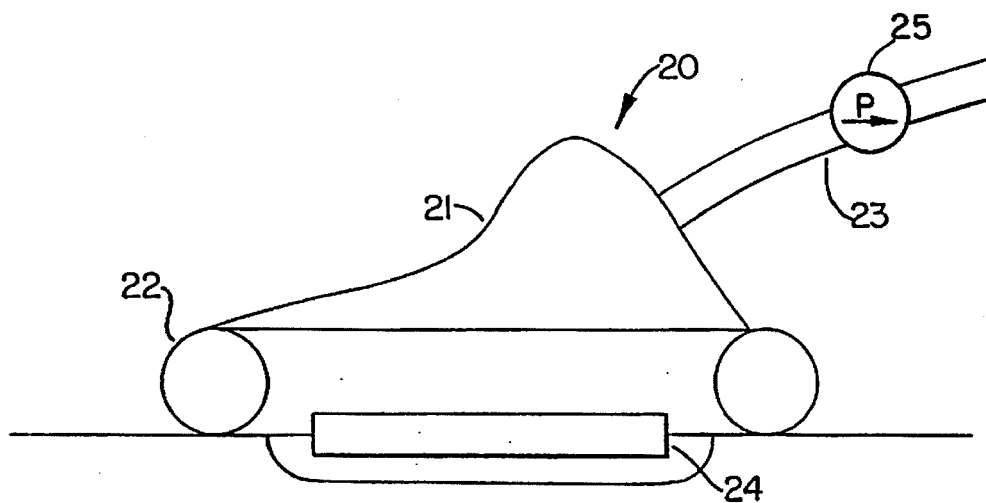

FIG. 2.

METHOD OF TREATING TISSUE DAMAGE AND APPARATUS FOR SAME

FIELD OF THE INVENTION

This invention relates generally to wound healing, and more specifically is directed at wounds that are unlikely to heal completely under conventional methods.

BACKGROUND OF THE INVENTION

The treatment of open wounds that are too large to spontaneously close has been a troublesome area for many years. Wound closure requires that epithelial and subcutaneous tissue adjacent to the wound migrate toward and eventually close the wound. Some wounds are sufficiently large or infected that they are unable to close spontaneously. In such instances, a zone of stasis, an area in which localized swelling of tissues restricts the flow of blood to these tissues, forms near the surface of the wound. Without sufficient blood flow, the wound is unable to successfully fight bacterial infection and accordingly is unable to close spontaneously.

The most common technique for closure of open wounds has long been the use of sutures or staples. These mechanical closure methods provide tension on the skin tissue at the wound border that encourages epithelial tissue to migrate toward the wound and cover it. While suturing and stapling of wounds is widely practiced, it has a major drawback: the tensile force required to achieve closure with sutures or staples causes very high localized stresses at the suture insertion points, resulting in the rupture of the tissue at these points. Substantial rupture will eventually cause dehiscence in some wounds, which results in additional tissue loss. Moreover, some infected wounds harden and inflame to such a degree that closure by suturing is not feasible. Wounds not repairable by suturing or stapling generally require prolonged hospitalization, with its attendant high costs, and major surgical procedures, such as grafts of surrounding tissue. Examples of such wounds include large, deep, open wounds, pressure sores resulting from prolonged pressure, ulcers resulting from chronic osteomyelitis, and partial thickness burns that subsequently develop into full thickness burns.

To date, there has been no consistently satisfactory method for treating such wounds. What is needed is a method of closing the wound without the localized stresses that accompany suturing while at the same time treating any infection present in the wound along with a simple apparatus to carry out the method. Such a method and apparatus would reduce hospitalization and increase the probability of wound closure.

SUMMARY OF THE INVENTION

A first aspect of the invention is a method of treating tissue damage which comprises applying a negative pressure to a wound over an area sufficient to promote the migration of epithelial and subcutaneous tissue toward the wound and for a time period sufficient to facilitate closure of the wound. The method is particularly useful for treating pressure sores.

A second aspect of the invention is a method of treating a burn wound which comprises applying a negative pressure to the burn over an area and for a time sufficient to inhibit progression in the depth of the burn. The method is preferably used on a partial thickness burn soon after its infliction.

A third aspect of the invention is a method of treating tissue damage which comprises applying a negative pressure

to a wound for a time sufficient to reduce bacterial density in a wound. A preferred use of this method is its application to a wound for at least 3 days to reduce the bacterial density of an infected wound to the point at which surgical closure can be attempted.

A fourth aspect of the invention is a method of enhancing the attachment of adjacent tissue to a wound which comprises applying a negative pressure to a joined complex of wound and adjacent living tissue at a sufficient magnitude and for a sufficient time to promote the migration of epithelial and subcutaneous tissue toward the complex. A preferred use of this method is enhanced attachment of adjacent tissue to tissues of the wound edges. Another use is enhanced attachment of an open skin graft.

A fifth aspect of the invention is an apparatus for facilitating the healing of wounds which comprises vacuum means for creating a negative pressure on the area of tissue surrounding the wound, sealing means operatively associated with the vacuum means to maintain the negative pressure on the wound, and screen means for preventing overgrowth of tissue in the wound area. A preferred embodiment of the invention comprises a section of open-cell foam configured to be placed over a wound, a flexible tube inserted into the foam section for attachment to a suction pump, and a flexible polymer sheet overlying the foam section and tubing and configured to be adhered to the skin surrounding the wound.

BRIEF DESCRIPTION OF THE DRAWINGS

FIG. 1 shows a cross-sectional view of a negative pressure device comprising a open-cell polymer screen, a flexible hose connecting the foam section to a suction pump, and a flexible polymer sheet overlying the foam-hose assembly to provide the necessary seal; and

FIG. 2 shows a cross-sectional view of a negative pressure device comprising a porous screen, an inflatable cuff attached to a semi-rigid cup, and a flexible hose extending from a suction pump to a point within the sealed volume of the cup-cuff assembly.

DETAILED DESCRIPTION OF THE INVENTION

The present invention includes a method of treating tissue damage which comprises the stages of applying a negative pressure to a wound over an area sufficient to promote migration of epithelial and subcutaneous tissue toward the wound, with the negative pressure being maintained for a time sufficient to facilitate closure of the wound. Wound closure requires that epithelial and subcutaneous tissue migrate from the wound border toward the wound. The use of negative pressure provides tension on this border tissue that causes accelerated tissue migration. It has been observed that the use of the method also causes within the wound increased formation of granulation tissue, a matrix of collagen, fibronectin, and hyaluronic acid carrying macrophages, fibroblasts, and neovasculature that aids in healing.

The method is particularly suited for use on pressure sores. A pressure sore is a wound that develops due to constant compressive pressure on the skin surface and underlying tissue. Blood flow to the compressed tissue is restricted to the extent that the overlying tissue dies and subsequently allows the underlying tissue to become infected. The decrease of blood flow to the wound prevents a normal immune reaction to fight the infection, the presence of which prevents tissue migration from the wound border.

Pressure sores often occur on bedridden patients who are unable to feel the sore or to move sufficiently to relieve the contact pressure. Such wounds can become very serious, requiring extensive and repeated skin grafts; some are even fatal. As described above, application of negative pressure to the sore permits migration of wound border tissue to occur and thus allows sores to heal without these more drastic procedures.

The method can be practiced with the application of substantially continuous negative pressure, where the pressure is relieved only to change the dressing on the wound, or it can be practiced with the use of a cyclic application of pressure in alternate periods of application and non-application. The ratio of duration of application period to non-application period can be as low as 1:10 or as high as 10:1, but is most preferably 1:1. A preferred pattern is 5 minutes of pressure application followed by 5 minutes of relief.

The method is preferably practiced using a negative pressure ranging from 0.01 to 0.99 atmospheres, and more preferably practiced using a negative pressure ranging between 0.5 to 0.8 atmospheres. The time period for use of the method on a wound is preferably at least 12 hours, but can be, for example, 1 day, 2 days, 5 days, 7 days, 14 days, 30 days, or even longer. There is no upper limit beyond which use of the method is no longer beneficial; the method increases the rate of closure up to the time the wound actually closes.

The present invention also includes a method of treating damaged tissue which comprises the steps of applying a negative pressure to a wound for a time and at a magnitude sufficient to reduce bacterial density in the wound. Open wounds are almost always contaminated with harmful bacteria. Generally a bacterial density of 10^5 bacterial organisms per gram of tissue is regarded as infected. (It is generally accepted that at this level of infection, grafted tissue will not adhere to a wound).

These bacteria must be killed, either through the wound host's natural immune response or through some external method, before a wound will close. We have observed that application of negative pressure to a wound will reduce the bacterial density of the wound; it is believed that this effect is due to either the bacteria's incompatibility with a negative pressure environment or the increased blood flow to the wound area, as blood brings with it cells and enzymes to destroy the bacteria.

The method can be used to reduce bacterial density in a wound by at least half. More preferably, it can be used to reduce bacterial density by at least 1,000 fold. Most preferably, the method can be used to reduce bacterial density by at least 1,000,000 fold. The ranges of pressure magnitude and application duration are as described above, although Example 3 demonstrates dramatic reduction in wound contamination after a 4-day application of negative pressure. Pressure can be applied continuously or cyclically in the application/nonapplication ratios described above.

The present invention also includes a method of treating a burn which comprises the steps of applying a negative pressure to the burn over an area and for a time sufficient to inhibit formation of a full thickness burn. A partial thickness burn, one which has a surface layer of dead tissue and an underlying zone of stasis, is often sufficiently infected that it will transform within 24-48 hours into a full thickness burn, one in which all epidermal structures are destroyed. As explained above, the application of a negative pressure to the wound prevents the infection from becoming sufficiently

severe to cause destruction of the underlying epidermal structures. As above, the magnitude, pattern, and duration of pressure application can vary with the individual wound.

The present invention also provides a method for enhancing the attachment of living tissue to a wound which comprises the steps of first joining the living tissue to the wound to form a wound-tissue complex, then applying a negative pressure to the wound-tissue complex over an area sufficient to promote migration of epithelial and subcutaneous tissue toward the complex, with the negative pressure being maintained for a time period sufficient to facilitate closure of the wound. Attachment of living tissue to a wound is a common procedure that can take many forms. For example, one common technique is the use of a "flap", a technique in which skin tissue from an area adjacent to the wound is detached on three sides but remains attached on the fourth, then is moved onto the wound. Another frequently used technique is an open skin graft in which skin is fully detached from another skin surface and grafted onto the wound. The application of negative pressure to the wound-graft complex reduces bacterial density in the complex and improves blood flow to the wound, thereby improving the attachment of the grafted tissue.

The acceptable ranges of time, magnitude, and application/non-application ratio are as described above. Each of these variables is affected by the size and type of wound.

The present invention also includes an apparatus for facilitating the healing of wounds. In general, an apparatus is provided for facilitating the healing of wounds comprising vacuum means for creating a negative pressure on the area of skin including and surrounding the wound and sealing means operatively associated with said vacuum means for maintaining said negative pressure on said wound by contacting the skin surrounding said wound. More specifically, an apparatus comprises vacuum means such as a pump for creating a negative pressure on the area of skin surrounding the wound, sealing means such as an adhesive sheet operatively associated with the vacuum means for maintaining negative pressure on the wound by contacting the skin surrounding the wound, and screen means such as an open-cell foam section located within the sealing means for preventing the overgrowth of tissue in the wound area.

The screen means is placed over substantially the expanse of the wound to prevent its overgrowth. The size and configuration of the screen can be adjusted to fit the individual wound. It can be formed from a variety of porous semi-rigid materials. The material must be sufficiently porous to allow oxygen to reach the wound, and sufficiently rigid to prevent wound overgrowth. Most preferred is the use of an open-cell polymer foam, which permits direct connection of the screen means to the vacuum means through a flexible hose inserted into the foam. Such foam can vary in thickness and rigidity, although it is preferred that a spongy material be used for the patient's comfort if the patient must lay upon the device during its operation. It can also be perforated to reduce its weight. Another embodiment comprises a section of honeycombed polyethylene sheet cut to the shape of the wound.

Possible sealing means include a flexible sealing rim contacting the skin surrounding the wound, a flexible polymer sheet overlying the screen means and the vacuum means and attached to the skin through an adhesive applied to the sheet surface facing the skin, and an inflatable sealing cuff that conforms to the skin when inflated and that is held in place by the suction of the vacuum means. If an adhesive

sheet is used, it must have sufficient adhesion to remain in contact with the skin and form a seal under the negative pressure. Additionally, it must be sufficiently flexible to overlay the screen means and still conform to the skin around the wound. The sealing means also can include a semi-rigid cup that protects the wound from external contact. For example, a suitable cup-cuff assembly is provided by an adult CPR mask with an inflatable sleeve.

Suitable vacuum means includes any suction pump capable of providing at least 0.1 pound suction to the wound, and preferably up to 3 pounds suction, and most preferably up to 14 pounds suction, and a flexible hose that leads from the pump to a point within the pressurized volume created by the sealing means. The pump can be any ordinary suction pump suitable for medical purposes that is capable of providing the necessary suction. The dimension of the tubing are limited only by the pump's ability to provide the suction level needed for operation. A 1/4 inch diameter tube has proven suitable. The vacuum means may operate substantially continuously, or may operate cyclically with alternate periods of application and nonapplication of pressure to the wound.

A preferred embodiment of the invention, shown in FIG. 1, comprises a substantially flat section of open cell polyester foam section 10 (Fischer Scientific, Pittsburgh, Pa. 15219) sufficiently large to cover the wound and thus prevent wound overgrowth, a flexible hollow tube 11 (Fischer Scientific) inserted into the open cell foam section 10 and joined thereto with an adhesive and extending to attach at its opposite end to a Gast Vacuum pump 15 (Fischer Scientific), and an Ioban adhesive sheet 12 (Minnesota Mining and Manufacturing, St. Paul, Minn. 55144) overlying the foam section 10 and tubing 11 and adhered to the skin surrounding the wound, thus forming a seal that allows creation of a vacuum when the suction pump operates. Such an apparatus would most preferably be packaged in a sterile condition to ameliorate the need for sterilization of the apparatus prior to use (note that the adhesive sheet 12 could be packaged separately from the foam-tube assembly). A particular advantage of this configuration is its use with pressure sores: the device can be placed in the depths of the wound and the patient can lie upon it without either affecting the utility of the device or further damaging the wound. This becomes critical if the patient cannot be moved from this posture for other medical reasons.

The present invention is explained further in the following examples. These examples are provided for illustrative purposes only and are not to be taken as limiting.

EXAMPLE 1

Rate of Wound Healing under Negative Pressure

This example demonstrates the use of negative pressure to increase the rate of healing of full thickness defects by increasing vascularity and the amount of granulation tissue present.

Fifteen-kilogram pigs were obtained and conditioned for 1 week prior to use. The backs of the pigs were shaved and scrubbed for surgery. Two full thickness circular defects were created on the midline of the animals, 2.5 cm in diameter and 1 cm thick. Alginate impressions were taken of each defect to determine its volume. Cefazolin (Kefzol) (500 mg) was administered intramuscularly (antibiotic). The suction devices used, shown in FIG. 2, comprised an adult CPR

mask 20 (Doug Brown and Associates, Huntington Beach, Calif. 92648) comprising a semi-rigid cup 21 and inflatable cuff 22 in contact with the skin, an open cell polyester screen 24 overlying the wound, and a flexible 1/4 inch diameter hose 23 (Fischer Scientific) connected by a Nalgene tubing connector to a vacuum pump 25 (Fischer Scientific) and extending through a sealed hole in the cup. Each device was configured such that the suction hose ran from the cup on the animal up through a pulley suspended over the center of the pen and down to a vacuum trap bottle to collect any liquid exudate, then down to the vacuum pump. A suction device was attached over each defect, and suction (2-6 pounds vacuum) was applied to one of the devices. The devices were removed only so that impressions could be made of each defect. This procedure was continued until the volume of both defects was zero.

Table 1 shows data expressed as the amount of granulation tissue formed per day and as the percent difference in rate of granulation tissue formation. The data shows that in all cases the use of negative pressure increased the rate of wound closure and the formation of granulation tissue at a statistically significant rate.

EXAMPLE 2

Rate of Burn Healing under Negative pressure

This example was designed to demonstrate the use of continuous closed suction for the treatment of deep, partial thickness thermal burns (second degree burns).

The backs of 15 kg pigs were shaved and scrubbed for surgery. A 1.5 inch diameter brass rod was heated to 190° C. in an oil bath. The rod was pressed onto the pig's skin for 15 seconds following a well-known technique of relating depth of burn to time and temperature. Three burns were created over the spine of each pig, separated by 5 cm intervals. Suction apparatus cups of the configuration described above were placed over two of the burns, with silver sulphadiazine (Silvadine) cream, the standard antibiotic cream applied to human burns prior to excision of burned tissue, applied to the third. Cefazolin (Kefzol) (500 mg) was administered intramuscularly (antibiotic). Suction (2-6 pounds vacuum) was applied to one of the cups. A small (2 mm) punch biopsy was taken of the wounded area and examined histologically for depth of burn.

TABLE 1

Rate of granulation tissue formation for control and reduced pressure treated full thickness defects in pigs.			
Animal	Granulated Treatment	Tissue/Day(cc)	% Increase*
1	Suction	0.48	26.3
	Control	0.38	
2	Suction	1.16	28.9
	Control	0.90	
3	Suction	0.58	75.8
	Control	0.33	
4	Suction	0.71	65.1
	Control	0.43	
5	Suction	0.71	65.1
	Control	0.43	

*(Suction-Control)/Control

TABLE 2

Rate of reduction in bacterial density for control and reduce and pressure treated pigs (n = 5). Log Organisms Per Gram Tissue								
Treat- ment		Day 0	Day 1	Day 2	Day 3	Day 4	Day 5	Day 7
Control	Mean	8.44	8.04	8.17	7.13	7.13	8.82	7.08
	SD	+ .38	± .13	± .98	± .15	± .24	± 1.12	± .52
Vacuum	Mean	7.69	7.36	7.37	6.79	6.43	3.98	4.32
	SD	± .83	± .84	± 1.40	± .55	± .45	± 3.46	± 3.74

Biopsies were analyzed by a dermatopathologist who was not told the nature of the study. It was concluded that the suctioned tissue specimens were healthier and healing more quickly than non-suctioned specimens.

EXAMPLE 3

Reduction of Bacterial Density under Negative Pressure

This example illustrates the effects of continuous closed suction on the bacterial density of infected tissue.

Fifteen-kilogram pigs were shaved and prepared for surgery. Two 2.5 cm diameter defects were created on the dorsum of each pig using sterile technique, with a 7.5 cm interval retained between the edges of the defects. Hemostasis was obtained by electrocautery. One ml of culture broth containing 10^8 *Staph. aureus* organisms was injected just beneath the surface tissue in the center of each wound. Suction cups of the configuration described above were placed over each defect, and a T-shirt was placed over the animal. Suction (2-6 pounds vacuum) was applied 24 hours after surgery to only one of the defects, allowing each animal to act as its own control. No antibiotics were given during the course of the study.

Each day, a small (3 mm biopsy punch) piece of granulation tissue was removed from the center of each defect. The number of organisms present in the tissue was determined by weighing the tissue, homogenizing the tissue, serially diluting the supernatant, and plating the diluted supernatant on blood agar plates. Samples of the original broth were treated in an identical manner to determine effects of mechanical manipulations on bacteria viability. The procedure was performed until the wounds were healed.

Table 2 compares the bacterial density of treated wounds and control wounds over time. The data is expressed as the mean log of the number of viable organisms per gram of tissue as a function of time. Clearly, the application of negative pressure increases the rate at which bacteria are destroyed. Using 10^5 organisms per gram of tissue as a baseline for infection, the data show that on average a suctioned wound was disinfected after 4 days of treatment, while the average non-treated wound was still infected after 7 days.

EXAMPLE 4

Treatment of Pressure Sore With Negative Pressure

Mr. L. J. is a 45-year-old diabetic male who has been a paraplegic as the result of a gunshot wound for 12 years. He has a history of recurrent right ischeal fossa pressure sore and right trochanteric pressure ulcer. L. J. was admitted to the hospital for treatment and closure of the pressure sores. A flap was placed onto the wound and secured with sutures and staples.

The incisions of the flap dehiscd, resulting in a large, open wound. The tissues of the flap were very edematous and indurated. Nine days after the flap was detached, a negative pressure device was placed over the wound. The device comprised an open-cell polyester foam section (Fischer Scientific) approximately 1/2 inch in thickness attached to a suction pump by a flexible hose (Fischer Scientific) and covered and sealed by Ioban polymer sheet (Minnesota Mining and Manufacturing, St. Paul, Minn. 55144). A continuous vacuum of 5 psi was applied to the wound. The design of the device allowed the patient to lay comfortably on the device during operation.

The depth of the wound decreased dramatically. The devices were changed and the wound examined on a three times per week basis. Reduced pressure treatment was continued for 6 weeks, at which time the wound was healed.

EXAMPLE 5

Treatment of Pressure Sore With Negative Pressure

Mr. W. E. is a 51-year-old male who had both legs amputated at the hip approximately 20 years ago. He was afflicted with a large pressure sore in the buttocks region. The pressure sore had been present 7 months and measured 8 inches laterally and 3 in its greatest width. An open cell foam reduced pressure device as described in Example 4 was placed over the wound and a negative pressure of 5 psi was applied cyclically in alternate periods of 5 minutes on, 5 minutes off. The open cell foam device was used as the patient was lying on the device. The device was changed on a three times per week schedule.

After 5 weeks of treatment, the wound measured 3 inches laterally and 1.5 inches at its greatest width. At that point the wound was essentially healthy granulation tissue that accepted a cultured keratinocyte allograft and healed completely.

EXAMPLE 6

Treatment of Wound Dehiscence With Negative Pressure

Mr. C. L. is a 50-year-old male who had undergone a colostomy revision through a midline laparotomy. He was readmitted to the hospital for wound dehiscence and evisceration following forceful coughing. The abdominal wall was closed with Prolene mesh coverage. Six weeks after placement of the Prolene mesh, the wound was still open and measured 28 cm by 23 cm with sparse granulation tissue grown through the Prolene mesh. A large reduced pressure cup device of the type described in Example 1 with an underlying porous Aquaplast sheet (WFR/Aquaplast Corp., Wyckoff, N.J. 07481) was placed on the Prolene mesh/

wound surface and the space closed with a tent of Ioban. Five psi of continuous negative pressure was applied. The device was changed three times per week.

After 6 days, granulation tissue had grown through the Prolene mesh, totally covering the mesh. The patient was taken to the operating room where the surrounding tissue was undermined and grafted onto the wound to partially close the defect. Split thickness skin grafts were used to cover the remainder of the defect, and were placed on the bed of granulation tissue. The wound accepted 80% of the grafts, and the remaining areas closed with dressing changes alone.

EXAMPLE 7

Treatment of Ankle Osteomyelitic Ulcer With Negative Pressure

Mr. R. F. is a 39-year-old white male who had severe trauma to his left lower extremity secondary to a motor vehicle accident 10 years ago. He had contracted chronic osteomyelitis and an open ulcer with exposed bone of his left lateral ankle (lateral malleolar ulcer). Necrotic soft tissue and bone were surgically removed from the ankle. The patient was placed on a 2½ week course of antibiotics. The day after surgery, a reduced pressure device of the type described in Example 1 was placed over the wound, and a negative pressure of 5 psi was applied. The device was changed on a three times per week schedule. After 14 days of treatment, the wound was smaller and filled with granulation tissue. A split thickness skin graft was placed over the center of the defect and healed primarily.

EXAMPLE 8

Treatment of Burn With Negative Pressure

Patient B. is admitted with second and third degree burns over the face and upper extremities, including both hands, as a result of a house fire. A large mitten-shaped reduced pressure device of the type described in Example 4 is placed over the patient's right hand, with open cell foam inserts placed between the fingers to apply reduced pressure to the interdigit spaces. Three pounds of vacuum is applied cyclically in a pattern of 5 minutes on, 5 minutes off. The device is changed on a three times per week schedule. Treatment is continued until the necrotic tissue sloughs off or is excised, followed by split thickness skin graft placement.

The foregoing examples are illustrative of the present invention, and are not to be construed as limiting thereof. The invention is defined by the following claims, with equivalents of the claims to be included therein.

That which is claimed is:

1. An apparatus for facilitating the healing of wounds, comprising:

vacuum means for creating a negative pressure between about 0.1 and 0.99 atmospheres on the area of skin including and surrounding the wound;

sealing means operatively associated with said vacuum means for maintaining said negative pressure on said wound by contacting the skin surrounding said wound; and

screen means for positioning at the wound within the sealing means for preventing the overgrowth of tissue in the wound.

2. An apparatus according to claim 1, in which said screen means comprises an open-cell polymer foam.

3. An apparatus according to claim 1, in which said screen means comprises a flat, porous, semi-rigid member.

4. An apparatus according to claim 1, in which said sealing means includes a flexible sealing rim in contact with said skin surrounding said wound.

5. An apparatus according to claim 1, in which said sealing means includes a flexible polymer sheet overlying said screen means, said polymer sheet having adhesive on at least a surface facing the wound to attach and seal said polymer sheet to said surrounding skin.

6. An apparatus according to claim 1, in which said sealing means includes a sealing cuff in contact with said skin surrounding the wound.

7. An apparatus according to claim 6, in which said sealing cuff is inflatable.

8. An apparatus according to claim 1, in which said vacuum means includes pump means for providing at least 0.1 pounds suction.

9. An apparatus according to claim 1, in which said vacuum means includes a pump means for providing at least 3 pounds suction.

10. An apparatus according to claim 1, in which said vacuum means includes a pump means for providing at least 14 pounds suction.

11. An apparatus according to claim 1, in which said vacuum means operates continuously.

12. An apparatus according to claim 1, in which said vacuum means operates cyclically to provide periods of application and non-application of suction.

13. An apparatus according to claim 1 wherein said vacuum means supplies a negative pressure between about 0.3 and 0.99 atmospheres to the wound.

14. An apparatus according to claim 1 wherein said vacuum means supplies a negative pressure between about 0.5 and 0.99 atmospheres to the wound.

15. An apparatus according to claim 1 wherein said vacuum means supplies a negative pressure between about 0.5 and 0.8 atmospheres to the wound.

16. An apparatus for facilitating the healing of wounds, comprising:

vacuum means for creating a negative pressure on the area of skin including and surrounding the wound;

sealing means operatively associated with said vacuum means for maintaining said negative pressure on said wound by contacting the skin surrounding said wound, wherein said sealing means includes a semi-rigid cup configured to protect said wound from external contact; and

screen means for positioning at the wound within the sealing means for preventing the overgrowth of tissue in the wound.

17. An apparatus for applying negative pressure to a wound beneath a fluid-impermeable seal comprising:

an open cell polymer foam section for positioning beneath said seal configured to overlie the wound such that said negative pressure is maintained within said foam and applied to the wound; and

a flexible tube having an inlet end inserted into said open cell polymer foam section and an outlet end for extending from beneath said seal and for supplying said negative pressure; and

wherein said apparatus is in an aseptic package.

18. An apparatus for treating a wound, comprising:

an open-cell foam section configured to overlie the wound;

a fluid-impermeable cover overlying said foam section, said cover adapted to form a seal with skin surrounding the wound for maintaining negative pressure beneath said cover; and

a single tubular member having a first end inserted beneath at least a portion of the foam section and having a second end extending from beneath said cover to a location external to said cover for supplying negative pressure beneath the cover.

19. The apparatus of claim 18 wherein said open-cell foam section is configured to overlie only a region of said wound within the margin of said wound.

20. The apparatus of claim 18 wherein said first end of the tubular member is embedded within the foam section.

21. An apparatus according to claim 18 wherein said vacuum source supplies a negative pressure between about 0.3 and 0.99 atmospheres to the wound.

22. An apparatus according to claim 18 wherein said vacuum source supplies a negative pressure between about 0.5 and 0.99 atmospheres to the wound.

23. An apparatus according to claim 18 wherein said vacuum source supplies a negative pressure between about 0.5 and 0.8 atmospheres to the wound.

24. An apparatus for treating a wound, comprising:

a semi-rigid, fluid-impermeable cup for positioning over the wound and for maintaining a negative pressure upon said wound, said cup having only a single external fluid communication port;

sealing means for sealing said cup about the wound, said sealing means including a cuff for inflating and conforming to the surrounding skin to seal said cup in place by said negative pressure;

tubular means extending from said fluid communication port of said cup for supplying said negative pressure; and

screen means for positioning beneath the cup at the wound for preventing overgrowth of the wound.

25. The apparatus of claim 24 wherein said screen means is a porous sheet.

26. The apparatus of claim 24 wherein said screen means is an open-cell foam.

27. An apparatus for facilitating the healing of wounds, comprising:

vacuum means for creating a negative pressure on the area of skin including and surrounding the wound, wherein said vacuum means operates cyclically to provide periods of application and non-application of suction with the ratio of duration of application period to non-application period between about 1:10 and 10:1;

sealing means operatively associated with said vacuum means for maintaining said negative pressure on said wound by contacting the skin surrounding said wound; and

screen means for positioning at the wound within the sealing means for preventing the overgrowth of tissue in the wound.

28. An apparatus according to claim 27 in which the duration of said application period is about 5 minutes.

29. An apparatus according to claim 28 in which the duration of said non-application period is about 5 minutes.

30. An apparatus according to claim 23, in which said screen means comprises an open-cell polymer foam.

31. An apparatus according to claim 24, in which said screen means comprises a flat, porous, semi-rigid member.

32. An apparatus according to claim 27, in which said sealing means includes a flexible sealing rim in contact with said skin surrounding said wound.

33. An apparatus according to claim 27, in which said sealing means includes a flexible polymer sheet overlying said screen means, said polymer sheet having adhesive on at

least a surface facing the wound to attach and seal said polymer sheet to said surrounding skin.

34. An apparatus according to claim 27, in which said sealing means includes a sealing cuff in contact with said skin surrounding the wound.

35. An apparatus according to claim 34, in which said sealing cuff is inflatable.

36. An apparatus according to claim 27, in which said vacuum means includes pump means for providing at least 0.1 pounds suction.

37. An apparatus according to claim 27, in which said vacuum means includes a pump means for providing at least 3 pounds suction.

38. An apparatus according to claim 27, in which said vacuum means includes a pump means for providing at least 14 pounds suction.

39. An apparatus for facilitating the healing of wounds, comprising:

vacuum means for creating a negative pressure on the area of skin including and surrounding the wound;

sealing means operatively associated with said vacuum means for maintaining said negative pressure on said wound by contacting the skin surrounding said wound, wherein said sealing means comprises a fluid-impermeable cover; and

screen means for positioning at the wound within the sealing means for preventing the overgrowth of tissue in the wound.

40. An apparatus according to claim 39, in which said screen means comprises an open-cell polymer foam.

41. An apparatus according to claim 39, in which said screen means comprises a flat, porous, semi-rigid member.

42. An apparatus according to claim 39, in which said sealing means includes a flexible sealing rim in contact with said skin surrounding said wound.

43. An apparatus according to claim 39, in which said cover includes a flexible polymer sheet overlying said screen means, said polymer sheet having adhesive on at least a surface facing the wound to attach and seal said polymer sheet to said surrounding skin.

44. An apparatus according to claim 39, in which said sealing means includes a sealing cuff in contact with said skin surrounding the wound.

45. An apparatus according to claim 44, in which said sealing cuff is inflatable.

46. An apparatus according to claim 39, in which said vacuum means includes pump means for providing at least 0.1 pounds suction.

47. An apparatus according to claim 39, in which said vacuum means includes a pump means for providing at least 3 pounds suction.

48. An apparatus according to claim 39, in which said vacuum means includes a pump means for providing at least 14 pounds suction.

49. An apparatus according to claim 39, in which said vacuum means operates continuously.

50. An apparatus according to claim 39, in which said vacuum means operates cyclically to provide periods of application and non-application of suction.

51. An apparatus according to claim 50 in which said vacuum means provides periods of application and non-application of suction with the ratio of duration of application period to non-application period between about 1:10 and 10:1.

52. An apparatus according to claim 51 in which the duration of said application period is about 5 minutes.

53. An apparatus according to claim 52 in which the duration of said non-application period is about 5 minutes.

54. An apparatus for facilitating the healing of wounds, comprising:

vacuum means for creating a negative pressure on the area of skin including and surrounding the wound;

sealing means operatively associated with said vacuum means for maintaining said negative pressure on said wound by contacting the skin surrounding said wound; and

screen means for positioning at the wound within the sealing means, said screen means having a pore size sufficiently large to prevent the overgrowth of tissue in the wound.

55. An apparatus according to claim 54, in which said screen means comprises an open-cell polymer foam.

56. An apparatus according to claim 54, in which said screen means comprises a flat, porous, semi-rigid member.

57. An apparatus according to claim 54, in which said sealing means includes a flexible sealing rim in contact with said skin surrounding said wound.

58. An apparatus according to claim 54, in which said cover includes a flexible polymer sheet overlying said screen means, said polymer sheet having adhesive on at least a surface facing the wound to attach and seal said polymer sheet to said surrounding skin.

59. An apparatus according to claim 54, in which said sealing means includes a sealing cuff in contact with said skin surrounding the wound.

60. An apparatus according to claim 59, in which said sealing cuff is inflatable.

61. An apparatus according to claim 54, in which said vacuum means includes pump means for providing at least 0.1 pounds suction.

62. An apparatus according to claim 54, in which said vacuum means includes a pump means for providing at least 3 pounds suction.

63. An apparatus according to claim 54, in which said vacuum means includes a pump means for providing at least 14 pounds suction.

64. An apparatus according to claim 54, in which said vacuum means operates continuously.

65. An apparatus according to claim 54, in which said vacuum means operates cyclically to provide periods of application and non-application of suction.

66. An apparatus according to claim 65, in which said vacuum means operates cyclically to provide periods of application and non-application of suction with the ratio of duration of application period to non-application period between about 1:10 and 10:1.

67. An apparatus according to claim 66 in which the duration of said application period is about 5 minutes.

68. An apparatus according to claim 67 in which the duration of said non-application period is about 5 minutes.

69. An apparatus for treating a wound comprising:

an open-cell foam section configured to overlie the wound;

a cover overlying said foam section, said cover adapted to form a seal with skin surrounding the wound for maintaining a negative pressure beneath said cover;

a single tubular member having a first end inserted beneath at least a portion of the foam section and having a second end extending from beneath said cover to a location external to said cover; and

a vacuum source connected with the second end of the tubular member for supplying said negative pressure between about 0.1 and 0.99 atmospheres to the wound.

70. An apparatus according to claim 69 wherein said vacuum source supplies a negative pressure between about 0.3 and 0.99 atmospheres to the wound.

71. An apparatus according to claim 69 wherein said vacuum source supplies a negative pressure between about 0.5 and 0.99 atmospheres to the wound.

72. An apparatus according to claim 69 wherein said vacuum source supplies a negative pressure between about 0.5 and 0.8 atmospheres to the wound.

73. An apparatus according to claim 69 wherein said open-cell foam section is configured to overlie only a region of said wound within the margin of said wound.

74. An apparatus according to claim 69 wherein said first end of the tubular member is embedded within the foam section.

75. An apparatus for treating a wound comprising: an open-cell foam section configured to overlie the wound, said foam section having a pore size sufficiently large to prevent overgrowth of the wound;

a cover overlying said foam section, said cover adapted to form a seal with skin surrounding the wound for maintaining a negative pressure beneath said cover; and

a single tubular member having a first end inserted beneath at least a portion of the foam section and having a second end extending from beneath said cover to a location external to said cover for supplying said negative pressure beneath the cover.

76. An apparatus according to claim 75 wherein said open-cell foam section is configured to overlie only a region of said wound within the margin of said wound.

77. An apparatus according to claim 75 wherein said first end of the tubular member is embedded within the foam section.

78. An apparatus for treating a wound comprising: an open-cell foam section configured to overlie the wound;

a cover overlying said foam section, said cover adapted to form a seal with skin surrounding the wound for maintaining a negative pressure beneath said cover;

a single tubular member having a first end inserted beneath at least a portion of the foam section and having a second end extending from beneath said cover to a location external to said cover; and

a vacuum source for supplying a negative pressure on the area of skin including and surrounding the wound, wherein said vacuum source operates cyclically to provide periods of application and non-application of suction with the ratio of duration of application period to non-application period between about 1:10 and 10:1.

79. An apparatus according to claim 78 in which the duration of said application period is about 5 minutes.

80. An apparatus according to claim 79 in which the duration of said non-application period is about 5 minutes.

81. An apparatus according to claim 78 wherein said open-cell foam section is configured to overlie only a region of said wound within the margin of said wound.

82. An apparatus according to claim 78 wherein said first end of the tubular member is embedded within the foam section.

UNITED STATES PATENT AND TRADEMARK OFFICE
CERTIFICATE OF CORRECTION

PATENT NO. : 5,645,081
APPLICATION NO. : 07/792001
DATED : July 8, 1997
INVENTOR(S) : Argenta et al.

Page 1 of 1

It is certified that error appears in the above-identified patent and that said Letters Patent is hereby corrected as shown below:

Front page, [*] Notice "March 9, 2013"
should read -- June 10, 2014 --

Signed and Sealed this

Fourteenth Day of November, 2006

A handwritten signature in black ink on a light gray dotted background. The signature reads "Jon W. Dudas" in a cursive style.

JON W. DUDAS

Director of the United States Patent and Trademark Office

UNITED STATES PATENT AND TRADEMARK OFFICE
CERTIFICATE OF CORRECTION

PATENT NO. : 5,645,081
APPLICATION NO. : 07/792001
DATED : July 8, 1997
INVENTOR(S) : Louis C. Argenta and Michael J. Morykwas

Page 1 of 1

It is certified that error appears in the above-identified patent and that said Letters Patent is hereby corrected as shown below:

Claim 30, line 1, the numeral "23", should read --27--.

Claim 31, line 1, the numeral "24", should read --27--.

Signed and Sealed this

Nineteenth Day of August, 2008

A handwritten signature in black ink that reads "Jon W. Dudas". The signature is written in a cursive style with a large, looped initial "J".

JON W. DUDAS
Director of the United States Patent and Trademark Office